

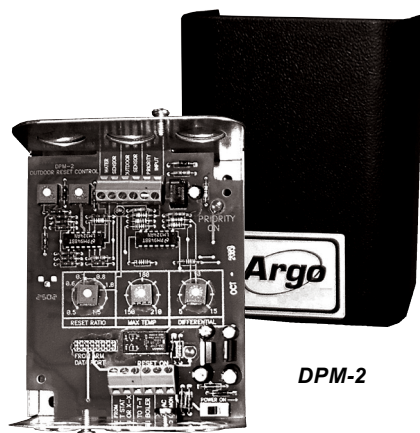

ARGO DPM-2 OUTDOOR TEMPERATURE SETBACK CONTROL

INSTALLATION, OPERATION & MAINTENANCE MANUAL



Information and specifications outlined in this manual in effect at the time of printing of this manual. ECR International, Inc. reserves the right to discontinue, change specifications or system design at any time without notice and without incurring any obligation, whatsoever.



Manufactured by:
ECR International Inc.
2201 Dwyer Avenue, Utica, NY 13501
Tel. 800 325-5479
www.ecrinternational.com
PN 240005132 Rev. D [11/15/2021]

TABLE OF CONTENTS

Safety Symbols and Warnings	3
Introduction.....	3
Product Description and Specifications.....	3
DPM-2 Control Board Diagram.....	4
Mounting Instructions	5
OutdoorSensorInstallation.....	5
WaterSupplySensorInstallation.....	5
Electrical Specifications & Wiring	6
DPM-2 Setup.....	6
Wiring Applications.....	7
Sequence of Operation	10
Troubleshooting.....	10
Replacement Parts.....	11
Technical Support	12

**Keep this manual near boiler
Retain for future reference**

Become familiar with symbols identifying potential hazards.



This is the safety alert symbol. Symbol alerts you to potential personal injury hazards. Obey all safety messages following this symbol to avoid possible injury or death.

DANGER

Indicates a hazardous situation which, if not avoided, **WILL** result in death or serious injury

WARNING

Indicates a hazardous situation which, if not avoided, could result in death or serious injury.

CAUTION

Indicates a hazardous situation which, if not avoided, could result in minor or moderate injury.

NOTICE

Used to address practices not related to personal injury.

WARNING

Fire, explosion, asphyxiation and electrical shock hazard. Improper installation could result in death or serious injury. Read this manual and understand all requirements before beginning installation.

WARNING

Fire, Explosion, Asphyxiation, Electrical shock hazard! Flooding will result in damages such as electrical problems, corrosion, inoperative parts, mold and other unforeseen issues which can occur over time. Any equipment determined by a professional as damaged by a flood, defined as excess of water or other liquid, shall be replaced. Failure to follow these directions will result in a Hazardous Situation.

IMPORTANT: Read and understand the following instructions **COMPLETELY** before installing!!

Introduction

This manual is intended to familiarize the installer and user of the Argo DPM-2 Outdoor Temperature Setback Control with its installation and operation to assure normal trouble-free operation.

Argo controls are designed and manufactured with quality components for maximum life and durability and require minimal service. To ensure a satisfactory installation, it is imperative that the instructions be followed carefully before operating the control. Failure to do so may result in breach of warranty.

Product Description And Specifications

DPM-2 Outdoor Temperature Setback Control is designed to raise or lower the temperature of boiler supply water based upon a proportionate drop or rise in temperature at the outside sensor. This control plugs into Argo control equipment with a data port or as a stand alone device that can be easily wired into almost any system.

DPM-2 CONTROL BOARD DIAGRAM

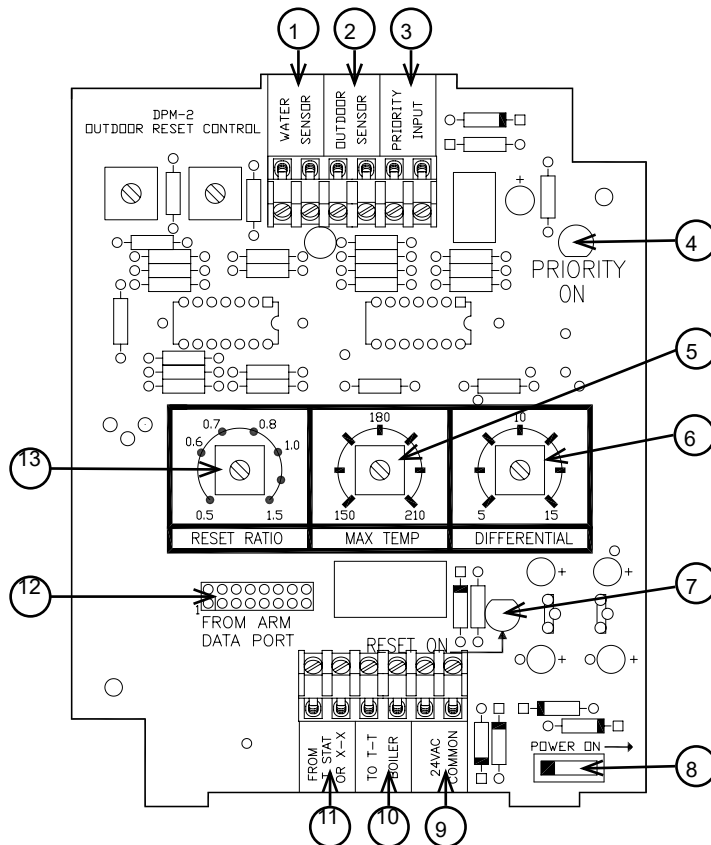

DIAGRAM KEY

1. Water Sensor Terminal Block
2. Outdoor Sensor Terminal Block
3. Priority Input Terminal Block
4. Priority LED
5. Max. Temp. Trim Pot
6. Differential Trim Pot
7. Reset On LED
8. Power Switch
9. 24 VAC "IN"/Common Terminal Block
10. To Boiler T-T Terminal Block
11. From T-Stat or X-X Terminal Block
12. Ribbon Cable Data Port
13. Reset Ratio Trim Pot

TECHNICAL SPECIFICATIONS

Power Supply: 20-28 VAC / 2 VA

Relay Capacity: 24 VAC / 48 VA

Sensor: 1005 Ohms at 70° F
(accurate up to 500' with 18 gauge wire)

*See "RTD Sensor Troubleshooting" in Section X for more information.

ADJUSTMENTS

Reset Ratio: 0.5-1.5

Max. Temp: 150°-210°

Differential: 5°-15°

Mounting Instructions

Mount the Argo DPM-2 Control vertically on a solid wall or partition. For your convenience it is recommended that the control be mounted as close as possible to the device being controlled, however it should never be mounted more than 75 feet away. Select a location that is easily accessible for installation and service.

NOTE: To reduce the possible transformer hum and relay noise that is sometimes amplified by mounting surfaces such as sheet metal, plasterboard, and similar materials, place rubber or felt washers between the case and the mounting surface.

1. Position the control and mark the mounting holes.
2. Start screws (not provided) for the keyhole type mounting holes in the upper corner(s). Tighten the screws down to about 1/8" (3mm) from the surface.
3. Hang the control on the screw(s), position the case, and start the bottom screws.
4. Tighten all screws.

Outdoor Sensor Installation

It is important to install outdoor sensor (provided with DPM-2) on the north side or shaded side of building. Locate minimum of 10 feet above grade and not near any location where internal heat could affect the sensor rating, such as window, doors, exhaust vents or fans. See figure below.

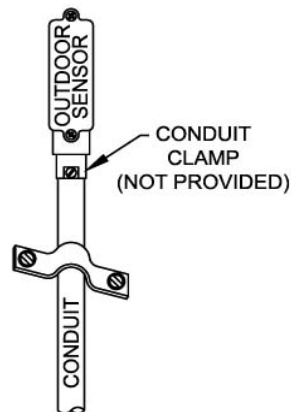

Water Supply Sensor Installation

Install supply water sensor on common header within 5 feet of supply water tapping in the boiler. See figure below.

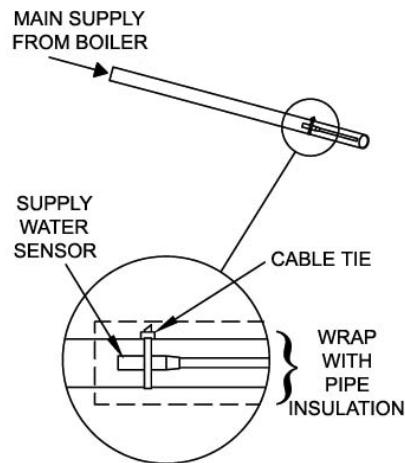

Electrical Specifications & Wiring

⚠ WARNING

Electrical shock hazard. Disconnect power before installing or servicing. Failure to follow these instructions could result in death or serious injury.

General Wiring Notice

All primary wiring must be 14 AWG minimum. Torque terminal screws 6 to 7 inch pounds.

U.S.A. - National Electric Code and any other national, state, or local code requirements. Wiring must be N.E.C. Class 1.

CANADA - C.S.A. C22.1 Canadian Electrical Code Part 1 and any other national, provincial, or local code requirements. Wiring must be C.S.A. C22.1 C.E.C. Part 1.

DPM-2 SETUP

Common Terminology

Reset Ratio: The ratio between supply water temperature and outdoor temperature. For example, a ratio of 1.0 or 1:1 means, for every one degree the outdoor temperature decreases, there will be a one degree increase in supply water temperature.

Max. Temp: The maximum supply water temperature when the outdoor temperature is 0°F.

Differential: Measurement used to determine when the boiler will turn on and off. A ten degree differential will turn the boiler on at five degrees below the control point and off at five degrees above while a twenty degree differential will turn the boiler on at ten degrees above and off at ten below. The effect of differential is to prevent quick cycling of the boiler.

DPM-2 Control Set-up

1. Determine the reset ratio and adjust "Reset Ratio Trim Pot." If heat curve is unknown, try ratio of 1.0.
2. Turn "Max. Temp. Trim Pot" to design temperature of supply water (water temperature needed when outdoor temperature is 0°F).

IMPORTANT: Boiler high limit must be set higher than "Max. Temp." setting plus "Differential" or unit may operate erratically.

3. Set "Differential Trim Pot" to scale (10°F). Boiler will turn off when water is 5°F above control point and back on again when water is 5°F below control point. If boiler does "Quick Cycle," increase trim pot. Optimal performance is obtained when this setting is as low as possible, but still allows for a reasonable cycle time.

**DPM-2 OUTDOOR TEMPERATURE SETBACK CONTROL
WITH ARGO AZ-3 ZONE VALVE CONTROL**

**TYPICAL WIRING APPLICATION USING DPM-2
OUTDOOR RESET WITH ARGO AZ-3 ZONE VALVE CONTROL**

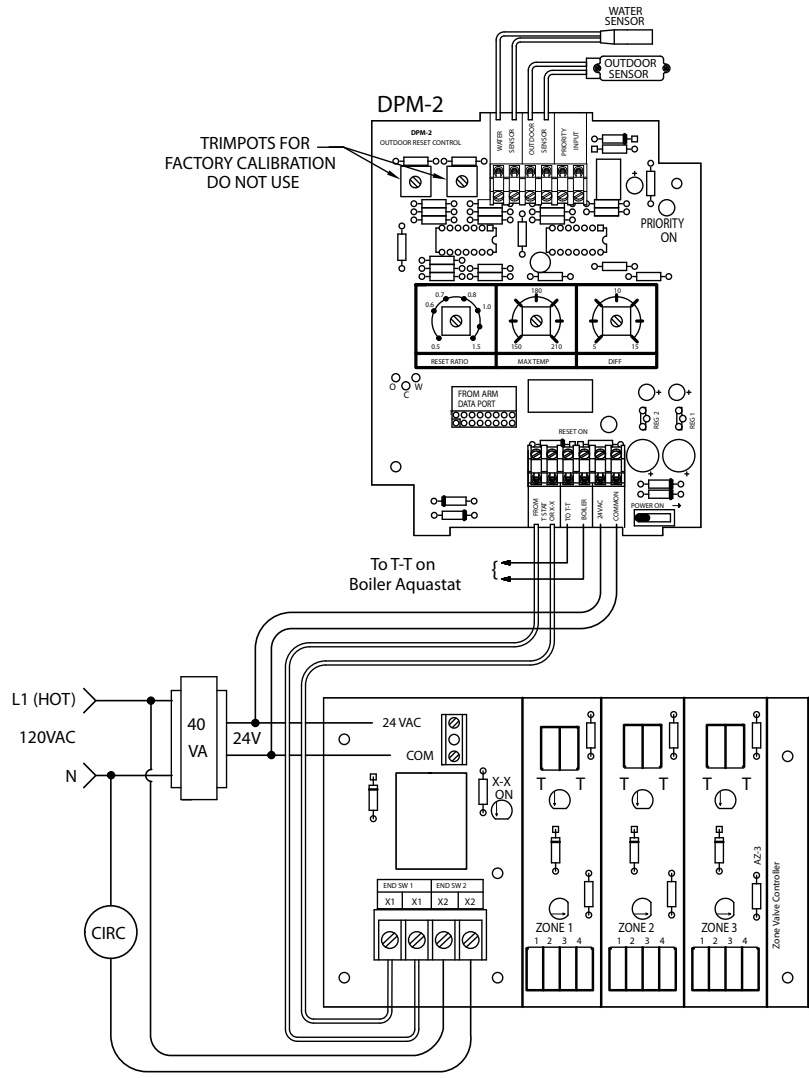

DPM-2 OUTDOOR TEMPERATURE SETBACK CONTROL WITH ARGO AZ-4CP CONTROL

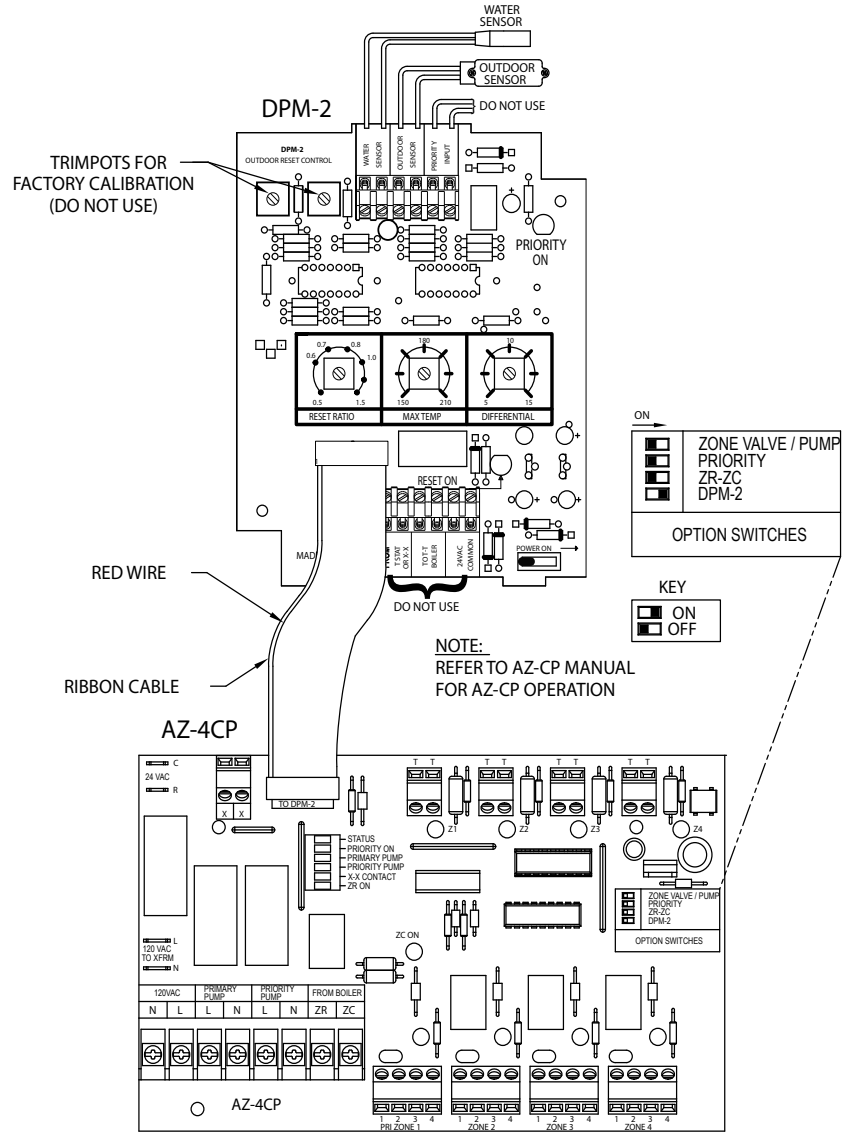

DPM-2 OUTDOOR TEMPERATURE SETBACK CONTROL WITH ARGO ARM-4P CONTROL

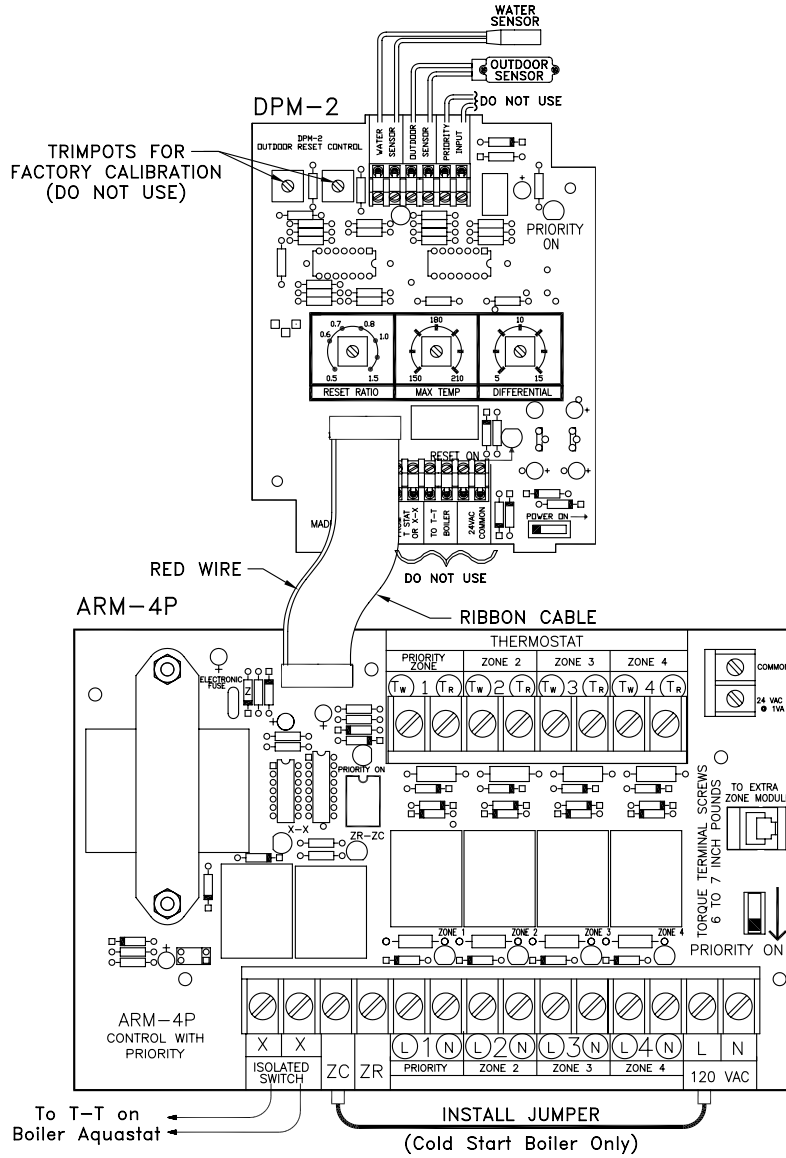

Sequence of Operation

DPM-2 is designed to operate in conjunction with several Argo controls via a ribbon cable but may also be used with other manufacturers' controls. The following assumes the application is a ribbon cable to standard zone control.

1. Zone control and boiler should be functioning properly in all respects prior to evaluating the DPM-2. Remove the ribbon cable and verify proper system operation before continuing.
2. Connect the DPM-2 to the zone control using the supplied ribbon cable in accordance with the wire diagram for your specific application (See Section VIII of this manual for examples.)
3. With the DPM-2 "Power On" switch in the "On" position, there should be 24 VAC across the lower terminals labeled "24 VAC and Common."
4. The high limit control on the boiler should be set to a higher temperature than the "Max. Temp." setting on the DPM-2. (See Section VII for more information.)
5. The "Priority On" LED should be on when the "Priority Zone" terminals on the zone control are jumped. The small relay near the LED should also be heard energizing.
6. When the DPM-2 "Reset On" LED is illuminated, the X-X relay on the zone control should be off. When the "Reset On" LED is off, the X-X relay should be on only if a zone is calling for heat.

RTD Sensor Troubleshooting

To confirm RTD Sensor is functioning properly:

1. Remove both RTD leads from the terminal block on the control board.
2. Use a multimeter to take an ohm reading across the RTD leads. A properly functioning RTD Sensor will produce a reading of approximately 1005 ohms at 70°F while a faulty RTD will read either "0" or "1."
3. Replace RTD if necessary.

Troubleshooting Tips

1. If the setup check is okay, a problem may be due to a faulty sensor, faulty installation, or faulty wiring.
2. Disconnect the sensor wires from the DPM-2 terminals and measure the resistance between the wires. The measured resistance should be within 5% of the values in the table below. If the meter indicates an open or short you might suspect the wiring between the sensor and the DPM-2.
3. If the outdoor sensor disagrees with another outdoor thermometer, it may be located in direct sunlight. Reposition the sensor if necessary. Do not proceed until both sensors are performing properly.

EXAMPLE: *If the water sensor reads 1500 ohms and you estimate the water is about 175°F, the water sensor is okay. If the meter reads 1400 ohms or 155°F, you might suspect the thermal connection between sensor and the pipe.*

OUTDOOR SENSOR		WATER SUPPLY SENSOR	
Degrees	Ohms	Degrees	Ohms
5	758	149	1368
14	789	158	1413
23	822	167	1459
32	855	176	1506
41	889	185	1554
50	924	194	1602
59	960	203	1652
68	997	212	1702
77	1035	-	-

NOTE: *The Outdoor Sensor and Water Supply Sensor are interchangeable and may be reversed to assist the troubleshooting process.*

Replacement Parts

REPLACEMENT PARTS	
DESCRIPTION	PART NUMBER
Temperature Sensor	Z63
Outdoor Sensor Shield	S60

Technical Support

For technical support on this and all Argo products, please contact ECR International Technical Service at 1-800-325-5479. Please have your model number available when calling.

Information Needed When Calling
Model Number
Installation Date
Installer



2201 Dwyer Avenue, Utica, NY 13501

Tel. 800 325-5479

www.ecrinternational.com

All specifications subject to change without notice.

©2021 ECR International, Inc.