

"AT" SERIES ELECTRIC HOT WATER BOILERS FOR FORCED HOT WATER



Argo



ARGO (Technical Support)
2201 Dwyer Avenue
Utica, NY 13501

(Corporate Sales)
85 Middle Road
Dunkirk, NY 14048
www.argoindustries.com

An  **ECR International Brand**
An ISO 9001-2000 Certified Company



INSTALLATION MANUAL AND OPERATING INSTRUCTIONS

P/N# I80, Rev. 3.5 [01/07]

TABLE OF CONTENTS

Safety Symbols	2
Warnings	3
Introduction.....	3
Product Description	3
Voltage Rating Tables.....	4
Installation Procedure.....	5
Design of Water Circulating System.....	6
Connecting Supply and Return Piping	6
Connecting Electrical Power Supply	8
Wiring Diagrams	11
Thermostat Installation	15
Startup and Seasonal Maintenance	15
Troubleshooting.....	16
Maintenance	17
Parts List - 2 Element Electric Boilers	18
Parts List - 4 Element Electric Boilers	19
Additional Wiring Diagrams	20
Modular Boiler Piping	23
Troubleshooting.....	24
"AT" Series Boiler Dimensions	27
Homeowner's Reference Table	28

KEEP THIS MANUAL NEAR BOILER
RETAIN FOR FUTURE REFERENCE

SAFETY SYMBOLS

The following defined symbols are used throughout this manual to notify the reader of potential hazards of varying risk levels.



Indicates an imminently hazardous situation which, if not avoided, WILL result in death or serious injury.



Indicates a potentially hazardous situation which, if not avoided, COULD result in death or serious injury.



Indicates a potential hazardous situation which, if not avoided, MAY result in minor or moderate injury. It may also be used to alert against unsafe practices.

IMPORTANT: Read the following instructions COMPLETELY before installing!!

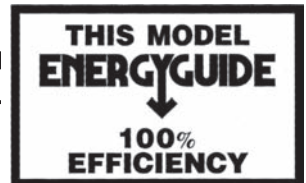

WARNINGS



WARNING



1. BOILER SIZING IS CRUCIAL. The maximum hourly heat loss for each heated space should be calculated in accordance with the procedures describes in The Hydronics Institute (I=B=R) manual H-22 (Heat Loss Calculation Guide), or by any other method which is suitable for local conditions, provided the results are in substantial agreement. Select the appropriate boiler based on accurate heat loss calculation. **DO NOT OVERSIZE THE BOILER, AS SIZING IS CRITICAL FOR IN-FLOOR RADIANT HEAT APPLICATIONS.**

2. Keep boiler area clear and free from combustible materials, gasoline and other flammable vapors and liquids.

3. DO NOT obstruct air openings to the boiler room.

4. Modification, substitution or elimination of factory equipped, supplied or specified components may result in property damage, personal injury or the loss of life.

5. TO THE OWNER: Installation and service of this boiler must be performed by a qualified installer.

6. TO THE INSTALLER: Leave all instructions with the boiler for future reference.

7. When this product is installed in the Commonwealth of Massachusetts the installation must be performed by a licensed plumber or licensed gas fitter.*

* In other areas, consult your local codes.



WARNING



All installations of boilers should be done only by a qualified expert and in accordance with the appropriate Argo manual. Installing a boiler or any other electric appliance with improper methods or materials may result in serious injury or death due to fire.

INTRODUCTION

This manual is intended to familiarize the installer and user of the Electric Hydronic Block with its installation, operation and maintenance so as to assure its normal trouble free operation.

Argo electric boilers are designed and manufactured with quality components for maximum life and durability and require minimum service. To insure a satisfactory installation it is imperative that the instructions be followed carefully before operating the heating system. Failure to do so may result in breach of warranty.

PRODUCT DESCRIPTION

The Electric Hydronic Block is a heating device that converts electrical energy to heat energy through the medium of water. The simplified theory of this conversion is as follows:

$$\text{Electrical Energy} \times \text{Conversion Factor} = \text{Energy}$$

– Or –

$$\text{Kilowatts Of Electricity Used Per Hour} \times 3412 = \text{British Thermal Units (Btuh) Available Per Hour For Heating.}$$

This information is the basis used to establish Electric Hydronic Block ratings (See Table 1 on page 4). Since the conversion process requires no combustion, the boiler operates with the highest possible efficiency.

The Electric Hydronic Block is constructed with a cast iron boiler that conforms to the American Society of Mechanical Engineers (ASME) Boiler & Pressure Vessel Code. The interior design allows just enough water to be present for proper heating element operation - no excess water is stored which would cause undesirable thermal losses and longer recovery times.

The control system is assembled in a modular package thus keeping the overall size and weight of the Electric Hydronic Block to a minimum. The construction of the entire Electric Hydronic Block conforms to Canadian Standards Association (CSA) Standards for Safety for Electric Boilers.

PRODUCT DESCRIPTION *Continued*

The following important product information is located on the cabinet cover:

- Model Number
- Manufacturer's Serial Number
- BTU Rating
- Heating Element Ratings
- Water Pressure & Temperature Limits
- CSA Listing
- ASME Stamp
- Total Amps
- Clearance

ARGO Electric Boilers are controlled by a electronic temperature controller. The controller controls the boiler water temperature with multiple stages and turns stages on based on the heating demand, and the preset boiler outlet water temperature. The controller also can control 120Vac circulating pumps rated up to 5A. When the thermostat calls for heat, the controller will operate the boiler to regulate the water temperature at a pre-selected set point. The system pump is on whenever there is a thermostat calling for heat.

VOLTAGE RATING TABLES

A - STANDARD 240V RATINGS

"AT" Series - 2 Element Boiler										
Model	Boiler Size Nominal KW	Operating Voltage (AC)	Net Heat Output BTU/Hr.	Power Input Watts	Total Heating Element Amperage	Number of Elements	Element Size (Watts)	Maximum Amperage Per Leg (1)	Suggested Wire Size (AWG) (2)(3)	Suggested Breaker Size (Amps) (3)
AT0623	6	240	20,472	6,000	25.0	2	3,000	31.0	8	40
AT0824	8	240	27,296	8,000	33.3	2	4,000	39.3	6	50
AT1025	10	240	34,120	10,000	41.7	2	5,000	47.7	6	60
AT1226	12	240	40,944	12,000	50.0	2	6,000	56.0	4	70
"AT" Series - 4 Element Boiler										
AT1243	12	240	40,944	12,000	50.0	4	3,000	56.0	4	70
AT1644	16	240	54,592	16,000	66.7	4	4,000	72.7	3	90
AT2045	20	240	68,240	20,000	83.3	4	5,000	89.3	2	100
AT2446	24	240	81,888	24,000	100.0	4	6,000	106.0	1	125

B - DE-RATED 208V RATINGS

"AT" Series - 2 Element Boiler										
Model	Boiler Size Nominal KW	Operating Voltage (AC)	Net Heat Output BTU/Hr.	Power Input Watts	Total Heating Element Amperage	Number of Elements	Element Size (Watts)	Maximum Amperage Per Leg (1)	Suggested Wire Size (AWG) (2)(3)	Suggested Breaker Size (Amps) (3)
AT0623	6	208	15,377	4,507	21.7	2	3,000	27.7	8	40
AT0824	8	208	20,502	6,009	28.9	2	4,000	34.9	8	50
AT1025	10	208	25,628	7,511	36.1	2	5,000	42.1	6	60
AT1226	12	208	30,753	9,013	43.3	2	6,000	49.3	6	70
"AT" Series - 4 Element Boiler										
AT1243	12	208	30,753	9,013	43.3	4	3,000	49.3	6	70
AT1644	16	208	41,005	12,018	57.8	4	4,000	63.8	4	90
AT2045	20	208	51,256	15,022	72.2	4	5,000	78.2	3	100
AT2446	24	208	61,507	18,027	86.7	4	6,000	92.7	1	125

(1) Allows for 6A control and accessory load in addition to heat load

(2) Type "THW" wire, copper only, check local codes (Sizes taken from C.E.C Table 2 & N.E.C. Table 310-16.)

(3) Actual wire and breakers need to be sized based on specific installation requirements in accordance with National Electrical Code (NEC), Canadian Electrical Code (CEC), and local codes (where applicable).

INSTALLATION PROCEDURE

Improper installation, adjustment, alteration, service or maintenance can cause injury or property damage.

1. The installation must conform to the requirements of the authority having jurisdiction or, in absence of such requirements, to the latest revision of the Canadian Electrical Code, CSA C22.1 Part 1, and/or any local regulations in Canada, or the National Electrical Code, ANSI/NFPA to (Latest Edition) and/or any local regulations and codes in the USA. Reference should also be made to local Electric utility regulations and other codes in effect in the area in which the installation is to be made.
2. Where required by the authority having jurisdiction, the installation must conform to American Society of Mechanical Engineers Safety Code for Controls and Safety Devices for Automatically Fired Boilers, ANSI/ASME No. CSD-1.
3. **The Boiler is intended for indoor installation only and not subject to water spray or leakage.**



Do not install boiler UNDER potential water source.

(RULE OF THUMB: Water Under Wires.)

4. Electric Hydronic Block units are provided with mounting brackets for easy wall mounting. The unit may be mounted directly on the wall by the use of lag screws or anchor bolts through holes provided, or on a 3/4" plywood panel. On uneven walls, it is suggested that a mounting surface be provided such as two 2 x 4's.
5. Any surface of the Electric Hydronic Block **except the back** shall be mounted no closer than 20 inches to the wall surface on the left and 20 inches minimum to wall surface on the right or more, depending on plumbing. Allow sufficient room from the front of the unit to a door or wall to remove cover - at least 12 inches minimum.

Install unit with a minimum clearance from top of unit to ceiling of 16 inches. If minimum requirements of space are used, it is suggested that the enclosure be exposed to some means of ventilation. The electric Hydronic Block unit must be mounted level, using the top of the back plate as a leveling point.

6. When installed in utility room, the door should be wide enough to allow the largest boiler part to enter, or to permit replacement of another appliance such as a water heater.

Minimum clearances to combustible constructions are:

TOP	16 IN.
FRONT	12 IN.
LEFT SIDE	20 IN.
RIGHT SIDE	20 IN.
REAR.....	0 IN.

BOILER LOCATION & CLEARANCE DIMENSIONS

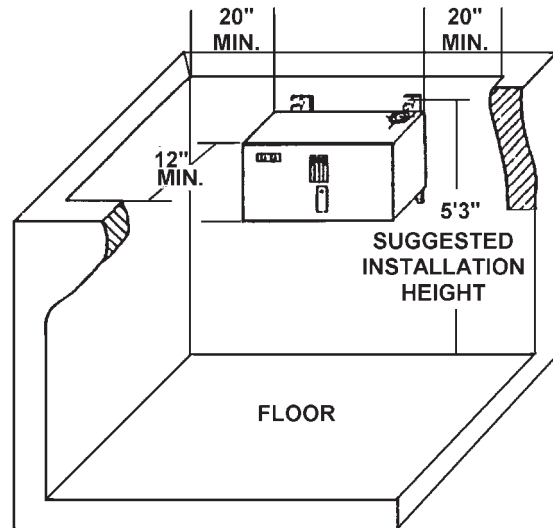

NOTE: Greater clearances for access should supercede fire protection clearance.

DESIGN OF WATER CIRCULATING SYSTEM

System should be designed as primary/secondary piping and to operate with a maximum output temperature of 180° F or lower and a temperature rise across the unit of 20° F or lower. Refer to tables below and Figures 2 & 3.

NOTE: To prevent condensation, the return water temperature must be higher than the room temperature in which the boiler is installed.

"AT" Series - 2 Element Boiler	
KW Capacity	Minimum Flow Rate (GPM)*
6	2.0
8	2.7
10	3.4
12	4.1

"AT" Series - 4 Element Boiler	
KW Capacity	Minimum Flow Rate (GPM)*
12	4.1
16	5.5
20	6.8
24	8.2

* Flow rate based on 20°ΔT

CONNECTING SUPPLY AND RETURN PIPING

1. Maintain a minimum clearance of one inch to hot water pipes.
2. Hot water boilers installed above radiation level must be provided with a low water cutoff device either as part of the boiler or at the time of boiler installation.

NOTE: In some states a low water cutoff device (LWCO) may be required. Check your local codes.

3. When a boiler is connected to a heating system that utilizes multiple zoned circulators, each circulator must be supplied with a flow control valve to prevent gravity circulation.

NOTE: Reduced pressure back flow provender must be present under provisions required by the Environmental Protection Agency, (EPA).

4. Suggested plumbing arrangements are illustrated in Figures 2 & 3. The inlet or return pipe is located

at the bottom of the unit. Reverse flow will result in a noisy operation and cause very early element failure. The drain cock is to be located at the lowest point of piping.

5. The outlet or supply pipe line to the radiation is located at the top of unit. A combination temperature pressure (altitude) gauge is provided with each unit and should be installed close to the boiler outlet. It is important that the gauge sensor be completely immersed in the flowing water so as to assure correct temperature readings. Manual or automatic water make up supply may be located in this area below. The circulator pump should be installed on the supply side (pumping away).
6. Gate valves should be installed at the locations shown in Figures 2 & 3, so that any boiler servicing requiring removal of water can be done quickly and easily. Not illustrated but also highly recommended is the installation of air vents at the high points of the hydronic system. These devices will reduce initial start up time and help avoid element burnout during the entire life of the heating system.
7. A pressure relief valve is supplied with each Electric Hydronic Block and should be installed at the location and discharge direction shown in **Figure 1**, using pipe nipple and elbow supplied. Piping should be added so that any water that may be discharged will not damage the boiler or other system components.

FIGURE 1

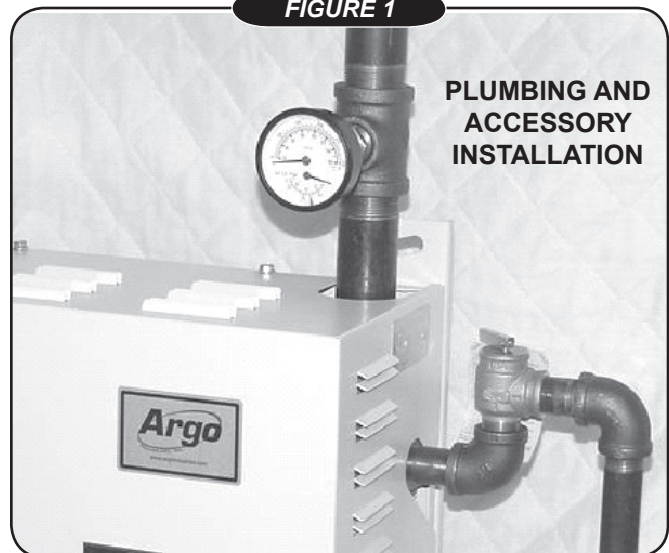

8. For further piping information refer to The Hydronics Institute (I=B=R) manual 200 (Installation Guide for Residential Hydronics).

FIGURE 2

**PRIMARY/SECONDARY PIPING FOR
MULTIPLE ZONING WITH CIRCULATORS**

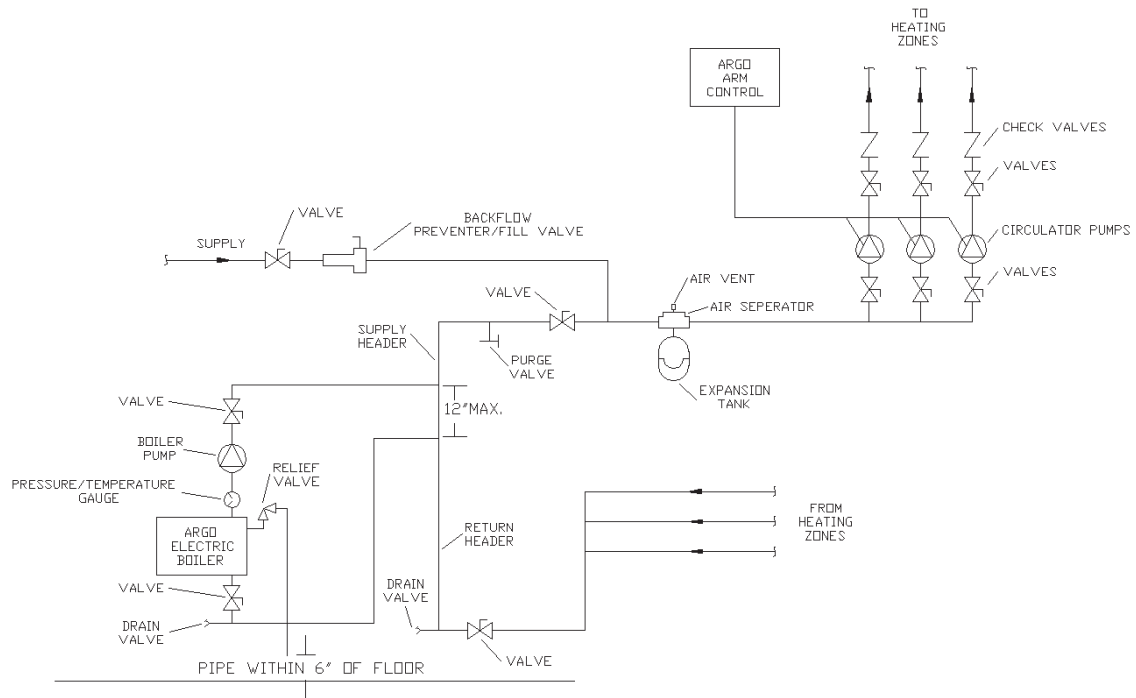
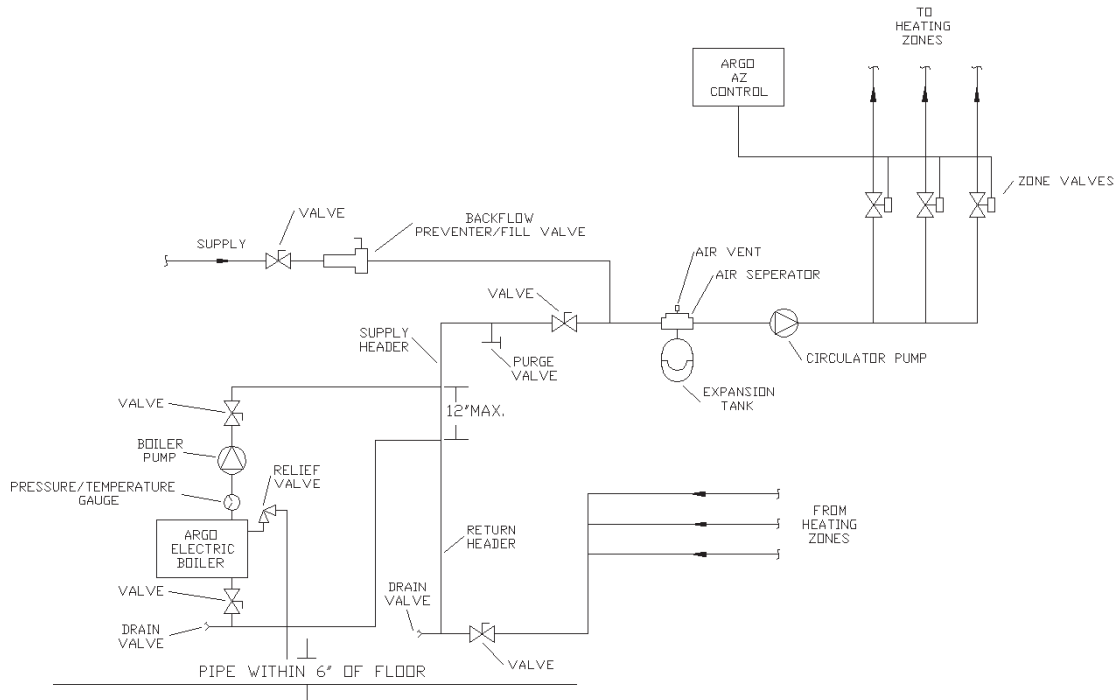

FIGURE 3

**PRIMARY/SECONDARY PIPING FOR
MULTIPLE ZONING WITH ZONE VALVES**



CONNECTING ELECTRICAL POWER SUPPLY

WIRING THE BOILER



WARNING

DO NOT USE ALUMINUM WIRE!!

Argo Electric Hydronic Boilers are pre-wired for use with 240-volt, 3 wire, single-phase, 50/60-hertz power. Refer to Table 1B on page 4 for the reduction in boiler capacity when the line voltage is less than 240 volts.

An opening is provided in the jacket bottom panel for the field wiring, refer to the rating chart for recommended wire sizes.

All electrical wiring must be done in accordance with the Canadian Electrical Code, CSAC22.1 Part 1, and /or any local regulations and codes in Canada, or the National Electrical code, ANSI/NFPA 70 (Latest edition) and/or any local regulations and codes in USA. Verify the nameplate rating and check the related codes to properly size conductors, switches and over current protection. Several openings are provided on the bottom of the cabinet for different voltage connections. For wire connections refer to the wiring diagram on the inside of the boiler front cover. **Do not use aluminum wire!!**

All circuit breakers or disconnects ahead of the boiler must be OFF. If boiler contains integral breakers (depending on option), it is recommended that they are also turned off at this time. Remove the boiler front cover by removing 4 screws from the top and sides.

When a boiler is used in a zoned system, the zone valves must be powered from an independent source and have electrically isolated end switches or isolating relays wired in parallel to the boiler thermostat terminals. **Do not attempt to power zone valves from the transformer in the boiler control system!!**

WIRING ON CONTROL

PUMP: Connect only 120 Vac 1/6 HP (maximum) pump to terminals C1(L) and C2(N) on the controller. Strip wire ends before inserting into terminal block. Tighten terminal screws. **Do not use a pump requiring greater than 5 amps!!**

THERMOSTAT: Connect thermostat or zone valve end switch to terminals TT and TT (**Figure 4**). **Do not apply an external power source to these terminals!!** Strip wire ends before inserting into terminal block. Tighten terminal screw clamps.

FIGURE 4

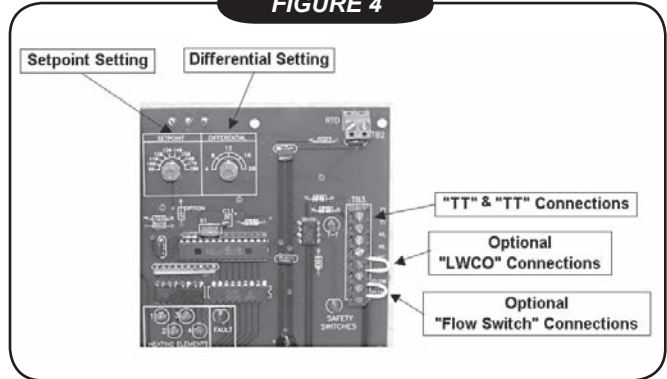
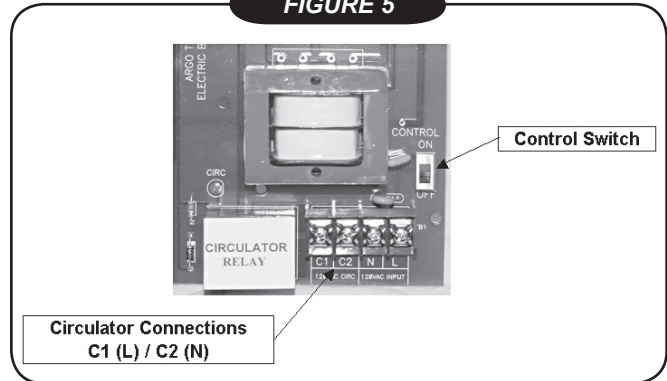

FIGURE 5



LIMIT CONTROL OPERATION

1. When the boiler water temperature exceeds the high limit setting on the aquastat, all heating element control relays are instantly de-energized. Circulator continues to operate until call for heat ends. When water temperature drops below aquastat re-set differential, heating element power relays close as per time delay sequence.
2. **MAIN POWER SUPPLY:** Depending on model designation, the electric Hydronic Block may be energized by the following alternating current service entrances: 240 volt single phase 50 or 60 cycle 3 wire. The wire size required may be selected from Table 1. The sizes listed for various capacity units include total amperes necessary to operate elements, circulator and zone valves where used. Wire sizes specified conform to the Canadian Electrical Code (Canada) or National Electric Code (USA) and include derating for

ampacity and temperature. **Use copper wire only with insulation rated for 75 °C.** Check state and local requirements.

NOTE: Read the data name plate before connecting unit so that you will become familiar with the specifications. All electrical connections to the unit are provided and located for ease of proper installation.

IMPORTANT: Use only copper wire of proper size and make sure all terminations are very tight. **Do not use aluminum wire!!**

3. CIRCULATOR POWER SUPPLY: Terminals identified as C1(L) and C2(N) at the bottom of the control panel (Figure 5) may be used to supply one circulator pump power. The circulator motor shall not be larger than 1/6 horsepower with a maximum 5.0 amp rating. Wiring from the control panel to the pump should have insulation rated at 75°C. Circuit protection is provided by a 15 amp breaker or fuse (depending on option) on the control board.

NOTE: If the circulator pump is larger than the maximum size listed above, then a separate circulator pump relay must be provided with separate overload protection. Where more than one circulator is used for zoning, it must be installed and protected according to approved electrical codes.

CONTROL INFORMATION

CONTROL BOARD SPECIFICATIONS:

Dimensions: 5-7/8"(W) x 9-3/8" (L) x 1-5/8" (H)
Operating Control Outlet Water Temperature:

90°F - 180°F (adjustable)

High Limit Control Outlet Water Temperature:

200°F (fixed)

Control Input Voltage: 120V ac

Control Output Voltage: 120V ac, 5A max. (circulator terminal)

POWER OUTPUT: One 120V ac pump output is switched by an onboard circulator relay. The load current is limited and must not exceed 5A.

CONTROL BOARD POWER CONSUMPTION: 0.8A max.

LED DISPLAY LIGHTS (Figure 6): A total of 8 LED indicator lights display the following information:

- (1) T-T (Green): LED is lit when thermostat is calling for heat.
- (2) Fault (Red): LED is lit/flashes when there is an operating error/safety fault.
- (3) Safety Switch (Green): LED is lit when there are no safety faults.
- (4) Circ (Green): LED is lit when circulator terminals are energized.
- (5) Heating Element#1 (Green): LED is lit when element#1 is energized.
- (6) Heating Element#2 (Green): LED is lit when element#2 is energized.
- (7) Heating Element#3 (Green): LED is lit when element #3 is energized.
- (8) Heating Element#4 (Green): LED is lit when element#4 is energized.

FIGURE 6

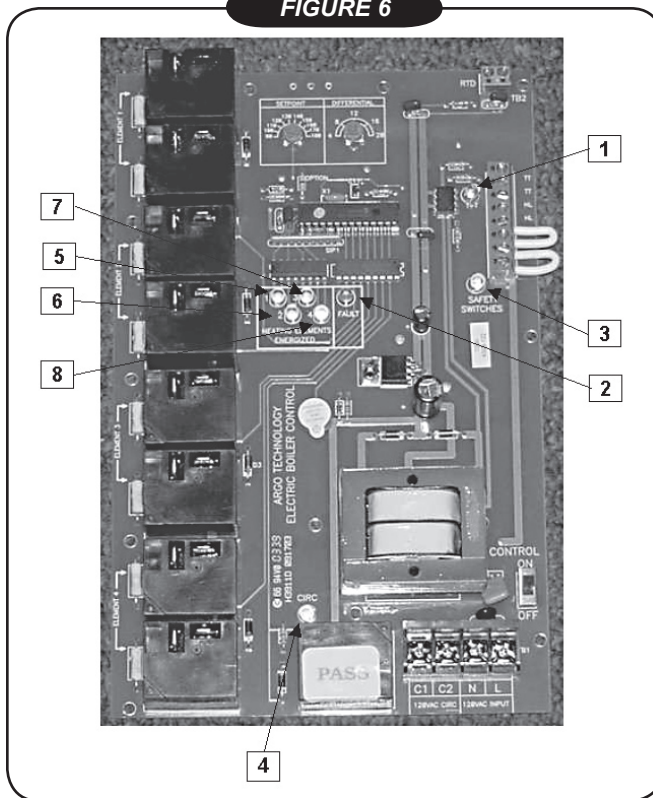

SIGNAL/CONTROL INPUTS:

TT: Thermostat or zone valve end switch, switching input, closed is activation.

HL: High limit temperature sensors (factory installed), normally closed.

LWC: Low water cutoff (optional) end switch, normally closed (factory installed jumper).

FLOW: Flow switch (optional) end switch, normally closed (factory installed jumper).

TEMPERATURE CONTROL RANGES:

Temperature: Degrees Fahrenheit
Operating Temperature Range:

90°F - 180°F
(Factory Setting: 180°F)

Operating Temperature Differential Range:

+/- 4°F - +/- 20°F
(Factory Setting: 12°F)

Fixed High Limit Temperature: 200°F

OPERATING TEMPERATURE AND DIFFERENTIAL ADJUSTMENTS: Internal temperature potentiometer on the control.

CONTROL OPERATION: When the control switch is in the "On" position and all safety end switches are closed, the "Safety Switch" LED is lit. Once in operating mode, the control uses the well-mounted (RTD) sensor to continuously monitor the boiler water temperature.

When the thermostat calls for heat ("TT" LED is lit), the control will energize the circulator ("Circ" LED is lit) for 30 seconds to establish flow. Next the control will measure water temperature and differential setting, perform a check for an "open" or "shorted" RTD sensor, check that all safety end switches are "closed," and check for stuck or welded element relay contacts. Next, the control will energize only one element ("Element" LED is lit) and monitor water temperature for 60 seconds. The control will energize additional elements at 30 second intervals to bring the system up to set point temperature in 5 minutes.

Once the system reaches the set point temperature and there is still a call for heat, the control will modulate the number of elements on and off in order to maintain the set point temperature. The required number of elements which are energized is determined by heating demand, which is the difference between actual boiler water temperature and set point temperature.

After the call for heat has been satisfied, the elements will be de-energized ("Element" LEDs turn off) by the control **and the circulator will continue to be energized for 3 minutes to purge the boiler.** After 3 minutes the control will de-energize the circulator ("Circ" LED turns off).

If at any time during the start-up of the boiler or during operation a safety end switch opens its respective contact, the control de-energizes all elements, continues to energize the circulator, and flashes a visible fault code ("Fault" LED flashes) along with an audible fault code. (See *fault codes (below)*) The control has a built-in reset function.

TEMPERATURE SETTING: The water "Set point" temperature adjustment dial on the control should always be set at the designed boiler water temperature.

CONTROL MOUNTING: The control is mounted using 1/2" tall plastic standoffs. The indicator LEDs are visible through a clear polycarbonate viewing window on front cover of the boiler.

PROTECTION FROM LIQUIDS: The control and other components located within the control panel are sensitive to water and other liquids. Measures must be taken to fully protect components on panel from contact with liquids.

FAULT CODES (VISUAL/AUDIBLE): RTD SENSOR:

To confirm that the RTD sensor is functioning properly, follow the steps below.

Number of Flashes/Pulses	Description
1	Safety switch fault
2	Stuck/welded element relay contact
3	RTD short
4	RTD open

1. Remove both RTD leads from the terminal block on the boiler control board.
2. Use a multimeter to take an ohm reading across the RTD leads. A properly functioning RTD will produce a reading of approximately 1000 ohms at 70° F. A faulty RTD will read either 0 or 1 on your multimeter.
3. Replace RTD if necessary.

WIRING DIAGRAMS

FIGURE 7A

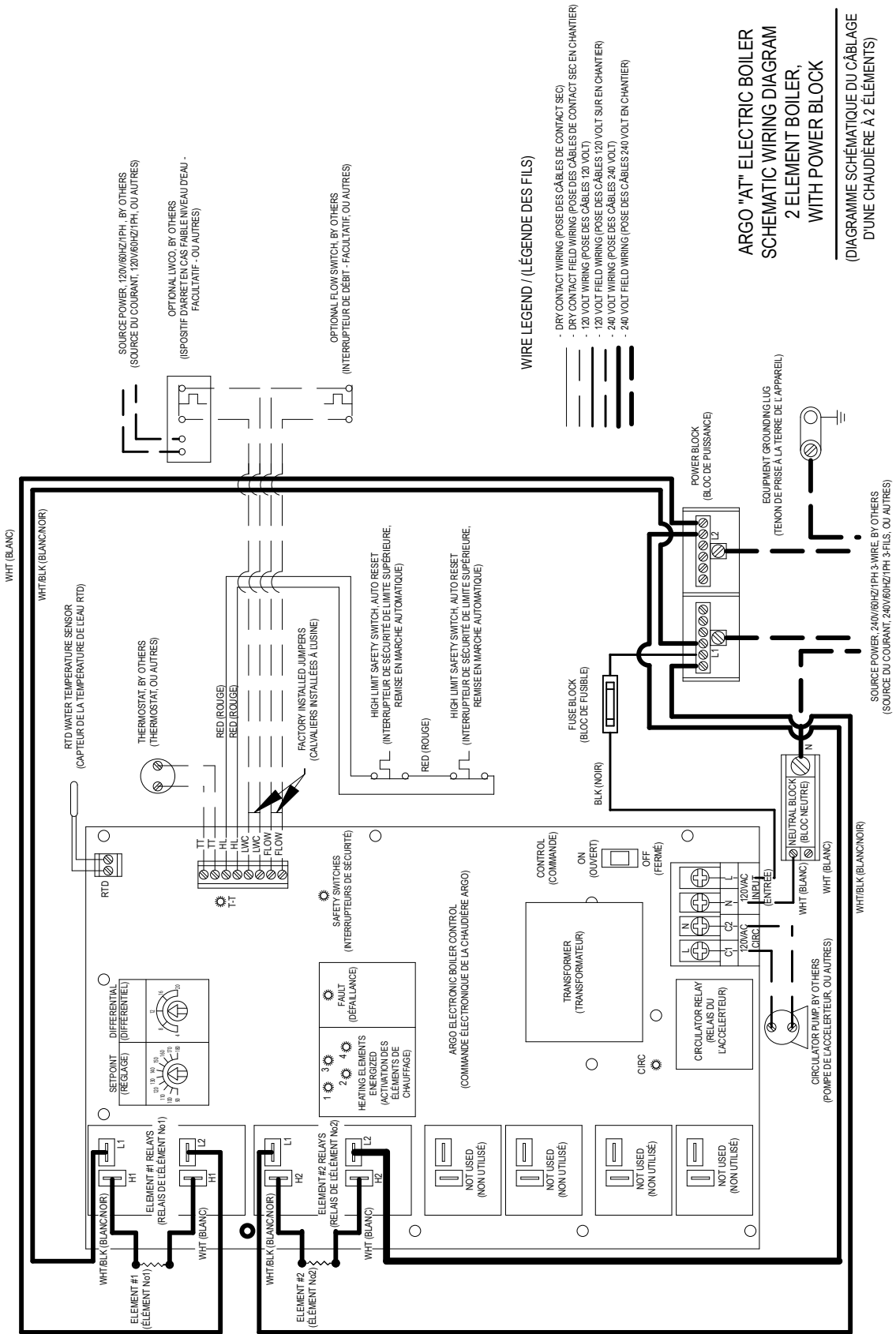

ARGO "AT" ELECTRIC BOILER
SCHEMATIC WIRING DIAGRAM
2 ELEMENT BOILER,
WITH POWER BLOCK
(DIAGRAMME SCHEMATIQUE DU CABLAGE
D'UNE CHAUDIERE A 2 ELEMENTS)

- WIRE LEGEND / (LEGENDE DES FILS)
- DRY CONTACT WIRING (POSE DES CABLES DE CONTACT SEC)
 - 120 VOLT FIELD WIRING (POSE DES CABLES DE CONTACT SEC EN CHANTIER)
 - 120 VOLT FIELD WIRING (POSE DES CABLES 120 VOLT)
 - 240 VOLT FIELD WIRING (POSE DES CABLES 240 VOLT SUR EN CHANTIER)
 - 240 VOLT FIELD WIRING (POSE DES CABLES 240 VOLT)

WIRING DIAGRAMS

FIGURE 7B

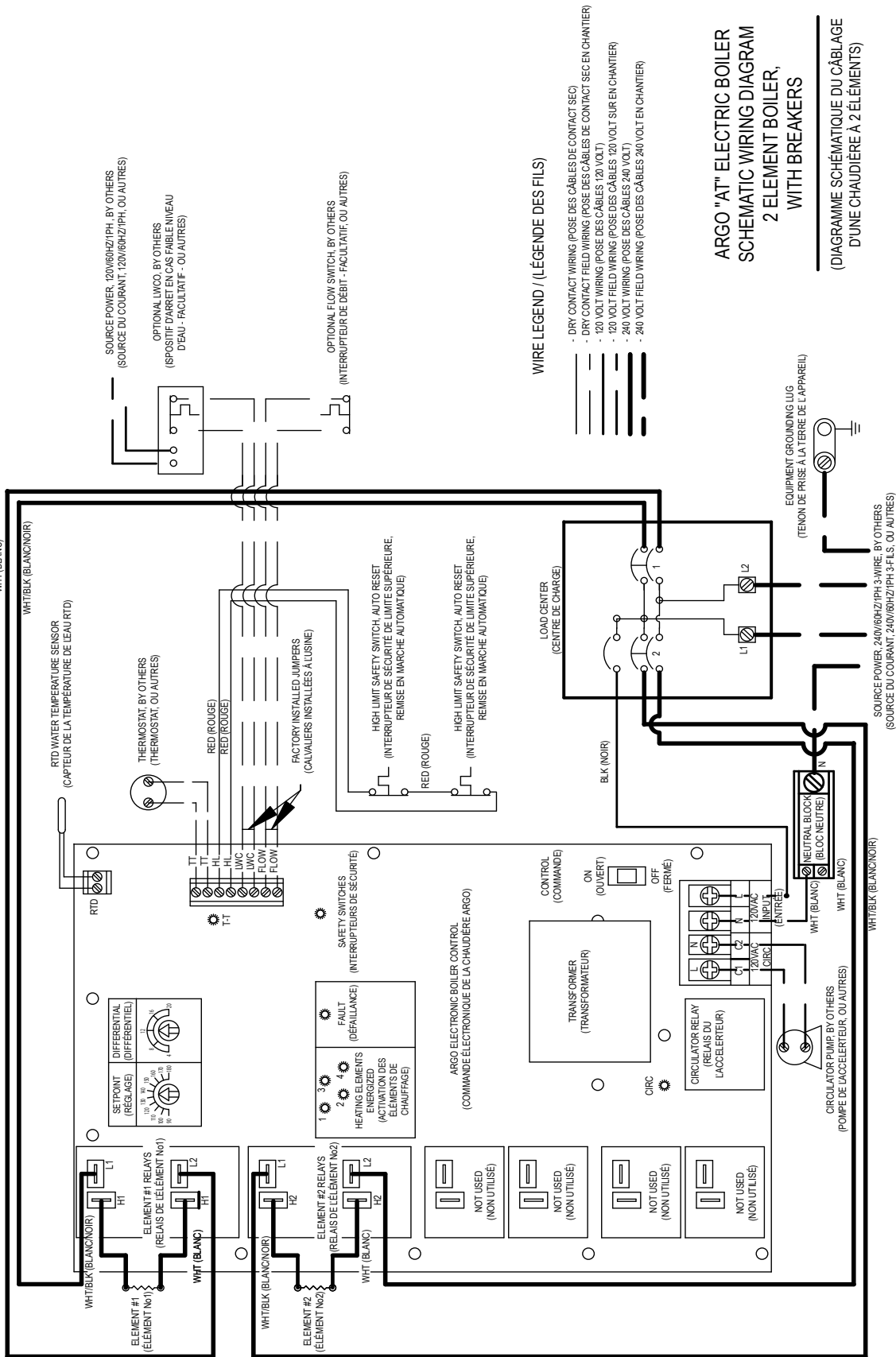

WIRING DIAGRAMS

FIGURE 8B

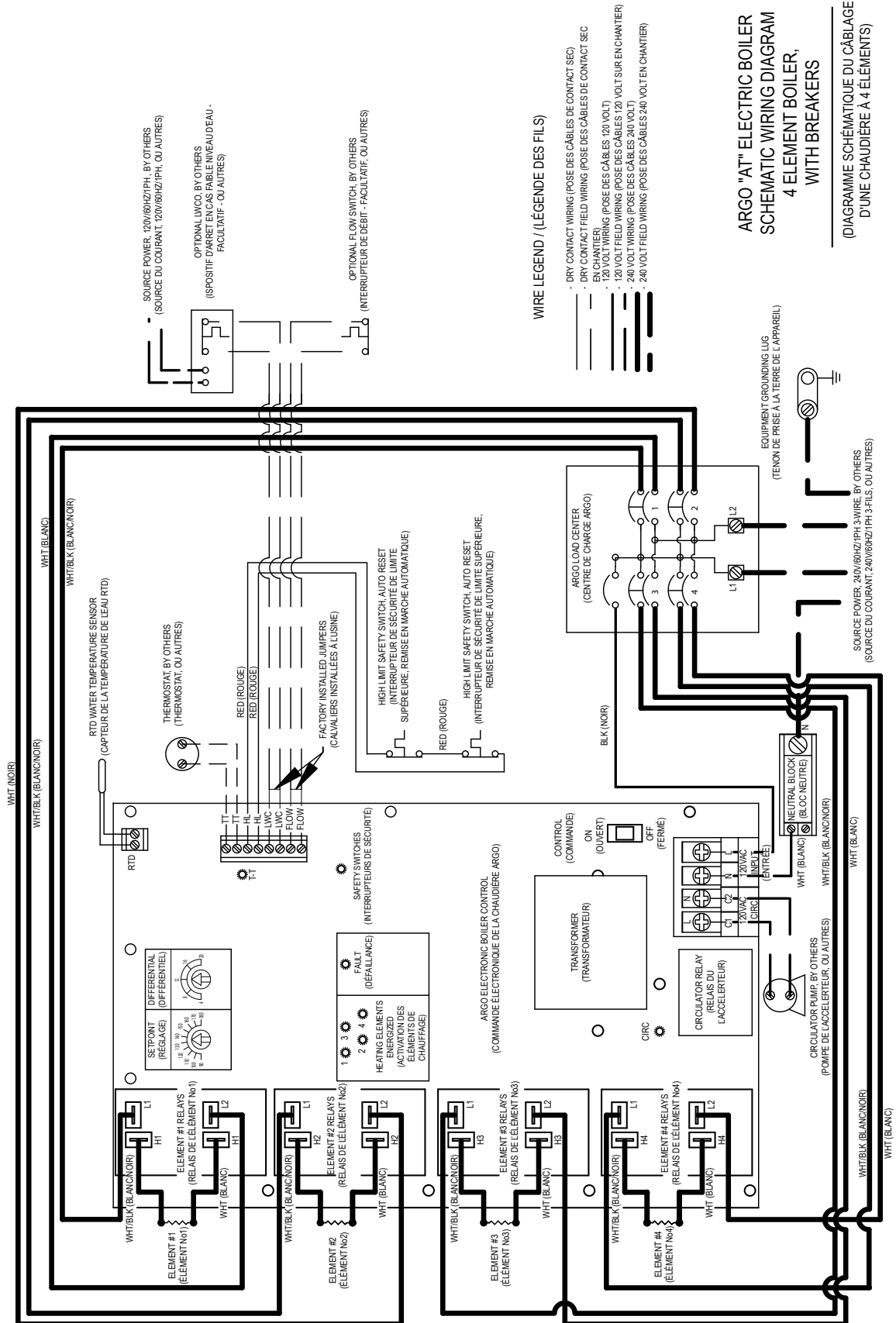

THERMOSTAT INSTALLATION

1. Thermostat should be installed on an inside wall about four feet above the floor.
2. NEVER install a thermostat on an outside wall.
3. Do not install a thermostat where it will be affected by sunlight, drafts, televisions, lighting fixtures, hot or cold pipes, fireplaces, or chimneys.
4. Instructions for final adjustment of the thermostat (adjusting heating anticipator, calibration, etc.) are packaged with the thermostat. **Recommended setting for the heating anticipator is 0.1 amps.**

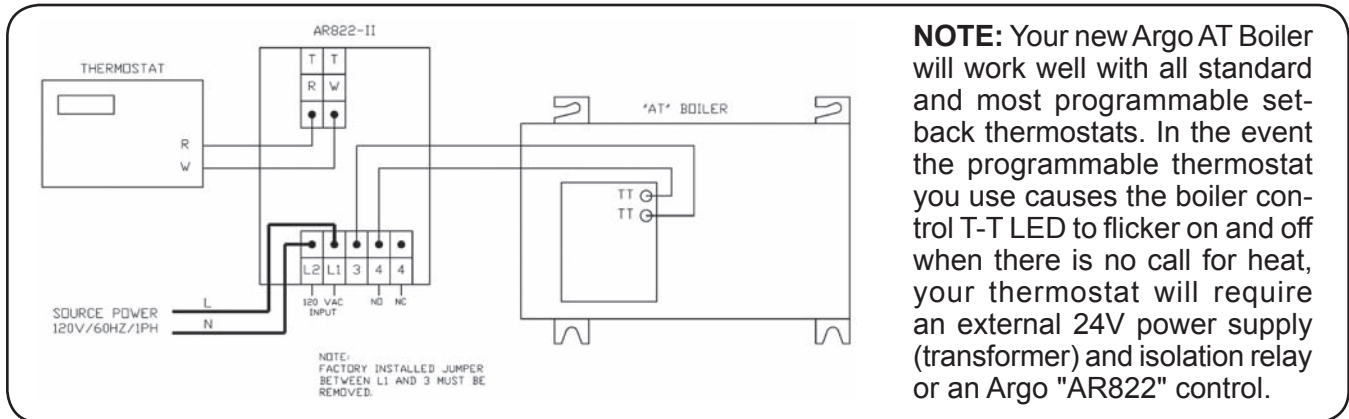

STARTUP AND SEASONAL MAINTENANCE

It is suggested that a qualified service agency be employed to make an annual inspection of the boiler and the heating system. They are experienced in making the inspection outlined below. In the event repairs or corrections are necessary they can make the proper changes for safe operation of the boiler.

⚠ CAUTION ⚠

Label all wires prior to disconnection when servicing controls. Wiring errors can cause improper and dangerous operation. Verify proper operation after service.

After all procedures have been carefully followed and completed, the hydronic block is now ready to be put into service.

1. Check hydronic block circuit breaker or switch at the service entrance and, depending on the option, the hydronic block circuit breakers within the unit to assure that they are in the "Off" position.

⚠ WARNING ⚠

Only propylene glycol can be used in heating system to prevent freezing. Recommendation is a maximum 40% or less propylene glycol mixture to ensure proper operation of electric boiler.

2. Fill the heating system with water until the pressure reaches 10-15 PSI. Check for leaks, repair if necessary, and purge all air from system.

⚠ CAUTION ⚠

Failure to vent and keep air out of the heating system will result in damage to heating elements in the hydronic block. Damage of this type is not covered by the manufacturer's warranty.

3. Set the boiler operating temperature to designed heating water temperature by adjusting the potentiometer dial located on the top center of the controller (*Figure 4*). Adjust arrow on temperature adjustment dial to the water temperature required.

NOTE: This boiler is also equipped with a high-limit temperature device set at 200°F as a safety limit control. The high limit temperature device has an automatic reset function and will reset at 170°F.

4. Turn on the hydronic block circuit breaker at the service entrance and/or disconnect switch and, depending on the option, the 15 amp circuit breaker on the hydronic block.
5. Set one thermostat above room temperature. The circulator pump will now operate.

6. Check system again for leaks. Allow circulator pump to run until all air has been vented from the system. A gurgling or rushing sound indicates the presence of air.
7. The hydronic block will now start to produce heat. As the water temperature increases, listen for air passing through the system. Water pressure will rise somewhat as temperature increases - this is normal as long as the pressure remains less than 25 PSI.
8. When the thermostat calls for heat, the circulator will be energized and the indicator LED will light up. Next, the heating elements are energized along with the element indicator LEDs. Once the boiler water temperature reaches the set point on the temperature adjustment dial, the controller will regulate the boiler by staging its elements. The number of elements which stay on is based on the heating demand and the set point of the boiler water temperature. After all room thermostats are satisfied with the heat, the controller de-energizes the elements one after another, and then switches the pump off after 3 minutes.

TROUBLESHOOTING

This section is meant to assist the service technician when trouble shooting the electric boiler. As in any trouble shooting procedure, it is important to isolate as much as possible before proceeding. Often the control error codes can be a great help indentifying cause of the problem. If you suspect a wiring fault, carefully check all external wiring and wiring connections following the wiring diagram label on the inside of the boiler's cover. An additional wiring diagram is included with this manual.

NOISY BOILER

1. Check water pressure of boiler. It should be between 15-25 PSI.
2. Check for air within the system.

⚠ WARNING ⚠

Extreme care must taken when the boiler cover is removed. Turn "OFF" all service to the boiler. "Power On" checks should be made by a qualified electrician.

CHANGING A HEATING ELEMENT

In the event it becomes necessary to change any heating element, use the following procedure:

2. Close gate valves near inlet and outlet of hydronic block.
3. Close feed line valve if using automatic fill.
4. Open drain valve and allow water to drain from the boiler. Manual operation of the relief valve will assist drainage by allowing air to enter.
5. Remove cabinet cover and disconnect the two wires attached to the effected heating element.
6. Remove the four bolts that secure the heating element to the casting and pry the element loose. Take note of the markings on the element flange to assure proper reinstallation.
7. After the element has been removed, carefully clean any remaining gasket material from the casting surface. Take care not to scratch or score this surface.
8. Install new gasket and heating element while assuring that the element is correctly positioned.
9. Close relief valve. Open feed line valve and check for leaks. Open gate valves. Install heating element wires and cabinet cover.
10. Refer to "Startup and Seasonal Maintenance" for proper purging of air prior to energizing the heating elements.

Problem	Cause	Solution
No heat when called by thermostat and "TT" LED is NOT lit	Thermostat	Disconnect thermostat from control, momentarily place a jumper across terminal "TT" & "TT." If circulator starts, trouble is in thermostat.
	No power to board	Confirm control's On/Off switch is in "ON" position, check 15A circuit breaker or fuse.
"Circ" LED is NOT lit when thermostat is calling	Safety fault	Check for open contact on safety's. Confirm continuity across terminals.
	No power to board	Confirm control's On/Off switch is in "ON" position
"Safety Switch" LED is NOT lit when thermostat is calling	Safety fault	Check for open contact on safety's. Confirm continuity across terminals.
	No power to board	Confirm control's On/Off switch is in "ON" position.
"FAULT" LED is flashing	Safety fault	Refer to "Fault" codes

MAINTENANCE

Because of its basic design, the hydronic block requires only a minimum of periodic maintenance. The preventive maintenance tasks described below are not difficult and when done a yearly basis, will aid the unit to continue its trouble free operation.

⚠ CAUTION ⚠

For safety reasons, the main power switch to the block should be turned off at the main service entrance before any work requiring removal of the cover is done. All work should be performed by qualified service personnel familiar with the unit's control system operation.

1. This boiler has been designed to provide years of trouble free performance under normal operating conditions. However, the owner should conduct a general external examination at the beginning of each heating season and at mid-heating seating season to assure good working performance is continued. In addition, a qualified service technician should examine at least once every year.
2. Do not store anything against the boiler or allow dirt or debris to accumulate in the area immediately surrounding the boiler.
3. Elements will burn out if the boiler is not filled with water when electrical power is turned on. Do not connect thermostat wire until system has been filled with water. Water should be drained out from system only when absolutely necessary to make repairs or prevent freeze-up during extended cold weather shutdown.
4. The temperature and pressure gauge on the system should be checked frequently. During normal operating conditions, pressure should be relatively stable throughout the heating season. If pressure under normal operating conditions consistently rises and falls over a period of time, this can indicate a fill valve leak, system leak, or compression tank malfunction. Leaks anywhere in the system must be repaired without delay. If any leaks or significant pressure fluctuations are observed, call for service immediately.
5. Check pressure relief discharge piping to assure that any discharged water will be properly routed to a suitable container or drain. Manually operate

the pressure relief valve by pulling the lever at the end of the valve until the lever is in line with the centerline of the valve. (Figure 9) Quickly close the valve to avoid losing an excessive amount of water. Repeat this procedure several times on a quick cycling basis to release any sediment that could block the relief valve pressure sensing mechanism. On heating system that use a manual water make-up or feed mechanism, be sure not to allow the system pressure to drop to 0 PSI when cycling the relief valve. Allowing this condition to occur could cause air to enter the system thus requiring a purging as described in "Startup and Seasonal Maintenance" on page 15.

FIGURE 9

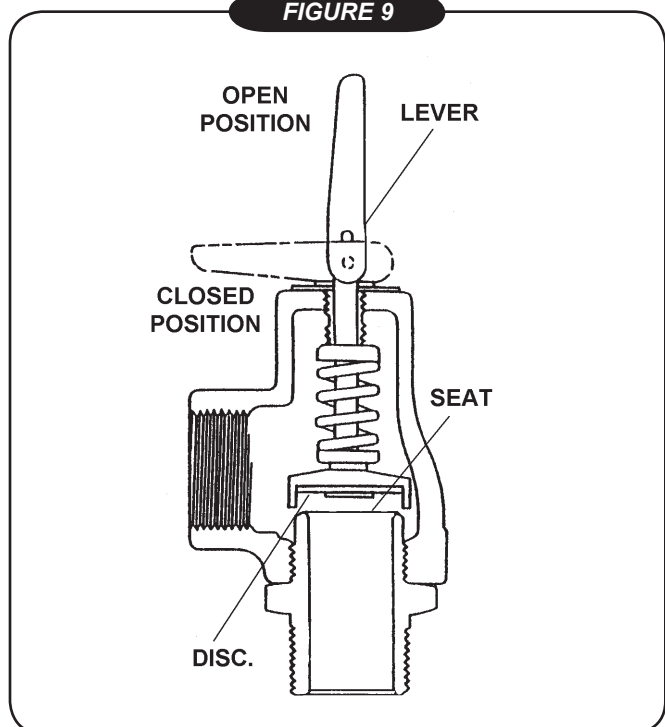

If the relief valve fails to completely close after cycling, it will be necessary to remove it for cleaning or replacement. Turn off power to boiler and isolate the hydronic block by shutting off the inlet and outlet gate valves. Reduce the water pressure to zero by opening the relief valve. Remove the relief valve and inspect the valve disc and seat. Cleaning these parts with a clean lint free cloth may be all that is necessary. If this procedure fails then replace the valve with a new one of equal pressure and discharge rating. After installing the cleaned or new relief valve, open the gate valves and follow the procedure described in "Startup and Seasonal Maintenance" on page 15.

PARTS LIST - 2 ELEMENT ELECTRIC BOILERS

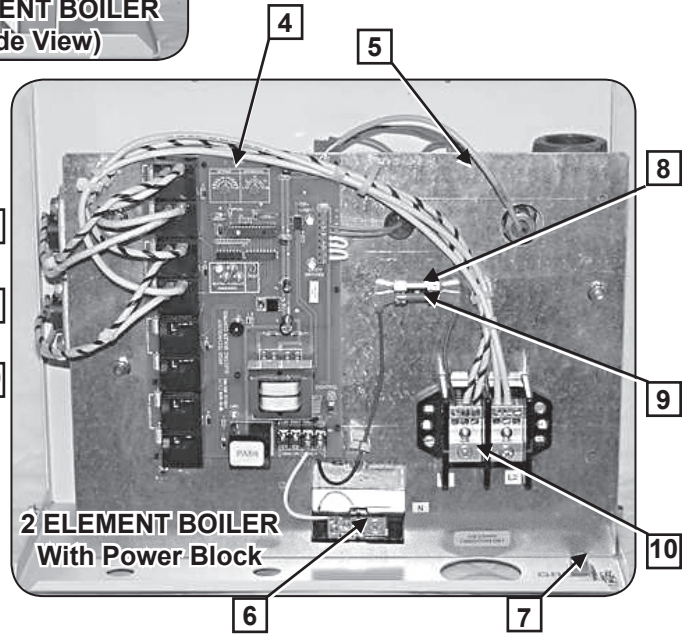
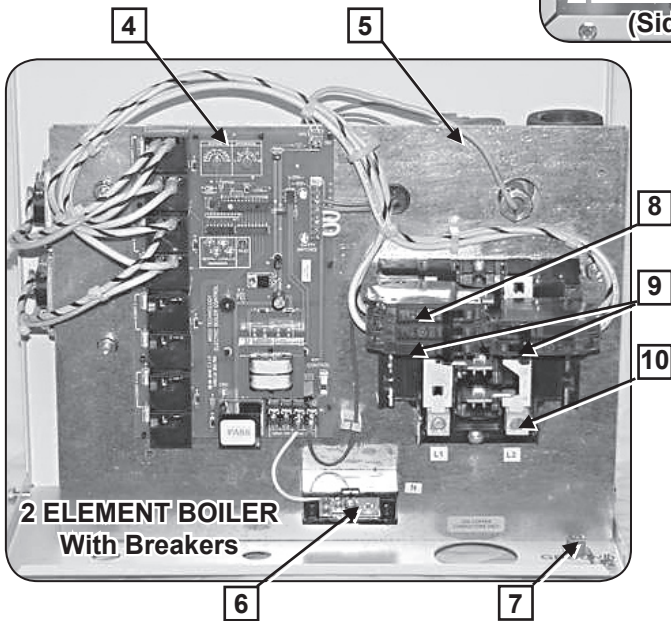
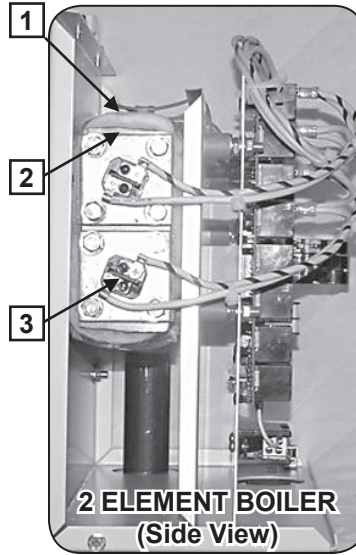

2 Element Electric Boiler w/Breakers		
Item	Part Number	Description
1	S47	Safety Limit Control (High Limit - Fixed Temp)
2	G12	Gasket - Heating Element
3	E13	Heating Element - 3 KW/240 Volt
	E14	Heating Element - 4 KW/240 Volt
	E15	Heating Element - 5 KW/240 Volt
	E16	Heating Element - 6 KW/240 Volt
4	Z3002	Control Board - 2 Element Boiler
5	Z64	RTD Sensor
6	B194	Neutral Terminal Block
7	L9	Ground Connection Lug
8	B28	Circuit Breaker 15 A - 1 Pole - G.E. THQP 115
9	B27	Circuit Breaker 40 A - 2 Pole - G.E. THQP 240
10	I25	Load Center Assembly - G.E. TLM812U2
-	V1	Relief Valve - 30 PSI
-	1260006	Temperature/Pressure Gauge
-	C57	Pressure Vessel - Cast Iron, 2 Element
-	Z302A	Control Panel Assembly, 2 Element (Complete)

2 Element Electric Boiler w/Power Block		
Item	Part Number	Description
1	S47	Safety Limit Control (<i>High Limit - Fixed Temp</i>)
2	G12	Gasket - Heating Element
3	E13	Heating Element - 3 KW/240 Volt
	E14	Heating Element - 4 KW/240 Volt
	E15	Heating Element - 5 KW/240 Volt
	E16	Heating Element - 6 KW/240 Volt
4	Z3002	Control Board - 2 Element Boiler
5	Z64	RTD Sensor
6	B194	Neutral Terminal Block
7	L9	Ground Connection Lug
8	F3	Fuse Block, 1/4" x 1-1/4" Fuse, 300V
9	F4	Fuse, 10amp, Ceramic, ABC-10
10	P8	Power Distribution Block
-	V1	Relief Valve - 30 PSI
-	1260006	Temperature/Pressure Gauge
-	C57	Pressure Vessel - Cast Iron, 2 Element
-	Z313	Control Panel Assembly, 2 Element (<i>Complete</i>)

PARTS LIST - 4 ELEMENT ELECTRIC BOILERS

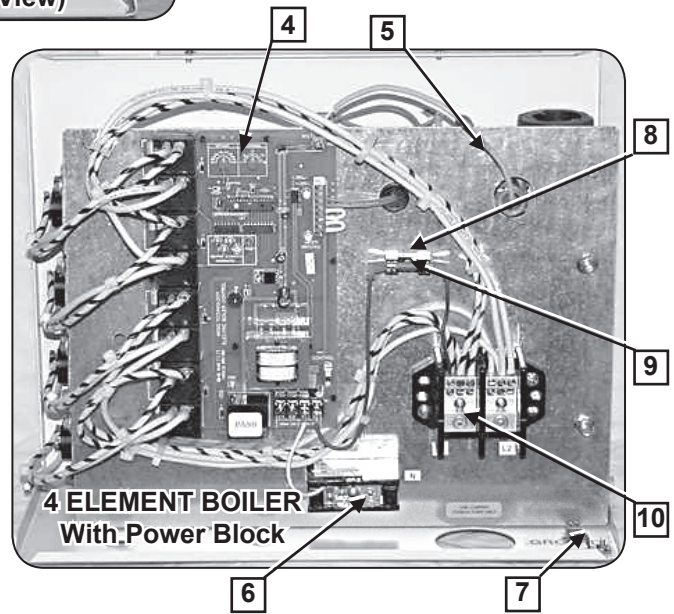
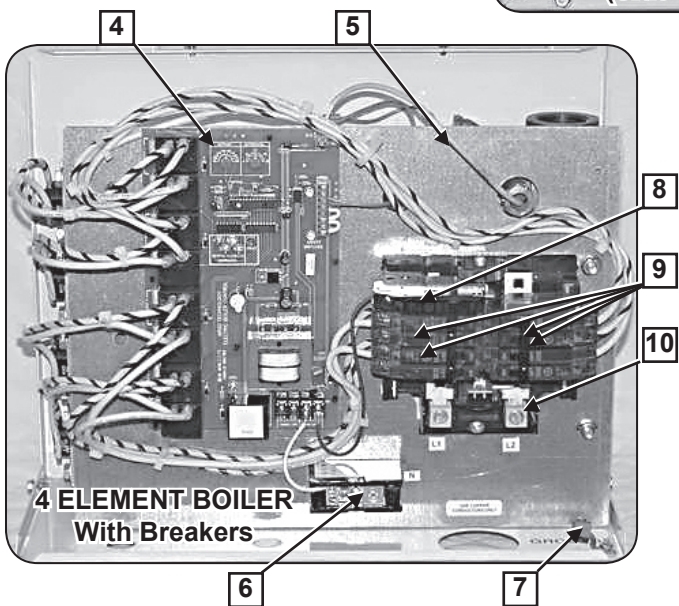
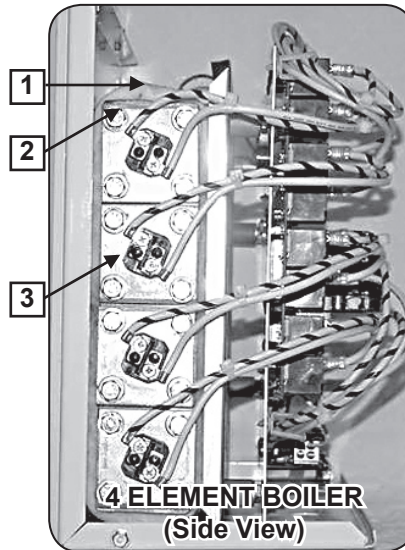

4 Element Electric Boiler w/Breakers		
Item	Part Number	Description
1	S47	Safety Limit Control (<i>High Limit - Fixed Temp</i>)
2	G12	Gasket - Heating Element
3	E13	Heating Element - 3 KW/240 Volt
	E14	Heating Element - 4 KW/240 Volt
	E15	Heating Element - 5 KW/240 Volt
	E16	Heating Element - 6 KW/240 Volt
4	Z300	Control Board - 4 Element Boiler
5	Z64	RTD Sensor
6	B194	Neutral Terminal Block
7	L9	Ground Connection Lug
8	B28	Circuit Breaker 15 A - 1 Pole - G.E. THQP 115
9	B27	Circuit Breaker 40 A - 2 Pole - G.E. THQP 240
10	I25	Load Center Assembly - G. E. TLM812U2
-	V1	Relief Valve - 30 P.S.I.
-	1260006	Pressure/Temperature Gauge
-	C32	Pressure Vessel - Cast Iron, 4 Element
-	Z304A	Control Panel Assembly, 4 Element (<i>Complete</i>)

4 Element Electric Boiler w/Power Block		
Item	Part Number	Description
1	S47	Safety Limit Control (<i>High Limit - Fixed Temp</i>)
2	G12	Gasket - Heating Element
3	E13	Heating Element - 3 KW/240 Volt
	E14	Heating Element - 4 KW/240 Volt
	E15	Heating Element - 5 KW/240 Volt
	E16	Heating Element - 6 KW/240 Volt
4	Z300	Control Board - 4 Element Boiler
5	Z64	RTD Sensor
6	B194	Neutral Terminal Block
7	L9	Ground Connection Lug
8	F3	Fuse Block, 1/4" x 1-1/4" Fuse, 300V
9	F4	Fuse, 10amp, Ceramic, ABC-10
10	P8	Power Distribution Block
-	V1	Relief Valve - 30 P.S.I.
-	1260006	Pressure/Temperature Gauge
-	C32	Pressure Vessel - Cast Iron, 4 Element
-	Z314	Control Panel Assembly, 4 Element (<i>Complete</i>)

ADDITIONAL WIRING DIAGRAMS

ONE SINGLE ZONE

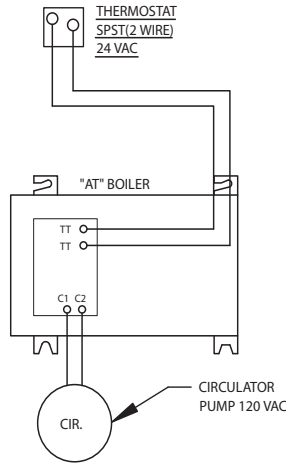

SINGLE ZONE WITH CIRCULATOR 2 BOILERS

ITEM NUMBER	DESCRIPTION
R35C	Relay 10A 24VAC
240004745	Relay Base, DIN Rail Mount
240004746	DIN Rail Approximately 2" Long

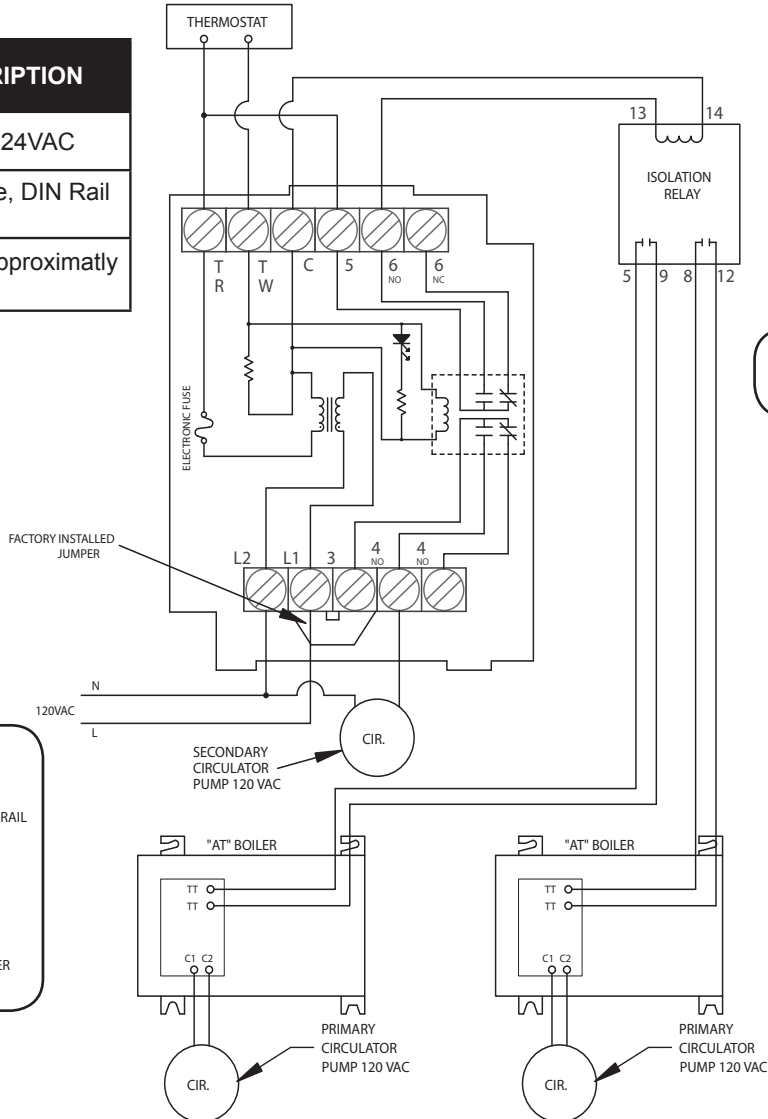

NOTE:
NUMBERS REFER TO NUMBER
DESIGNATIONS ON RELAY BASE, SEE BELOW.

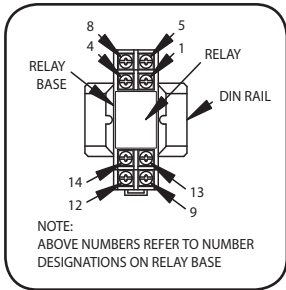

ADDITIONAL WIRING DIAGRAMS

TWO ZONES WITH CIRCULATORS 2 BOILERS

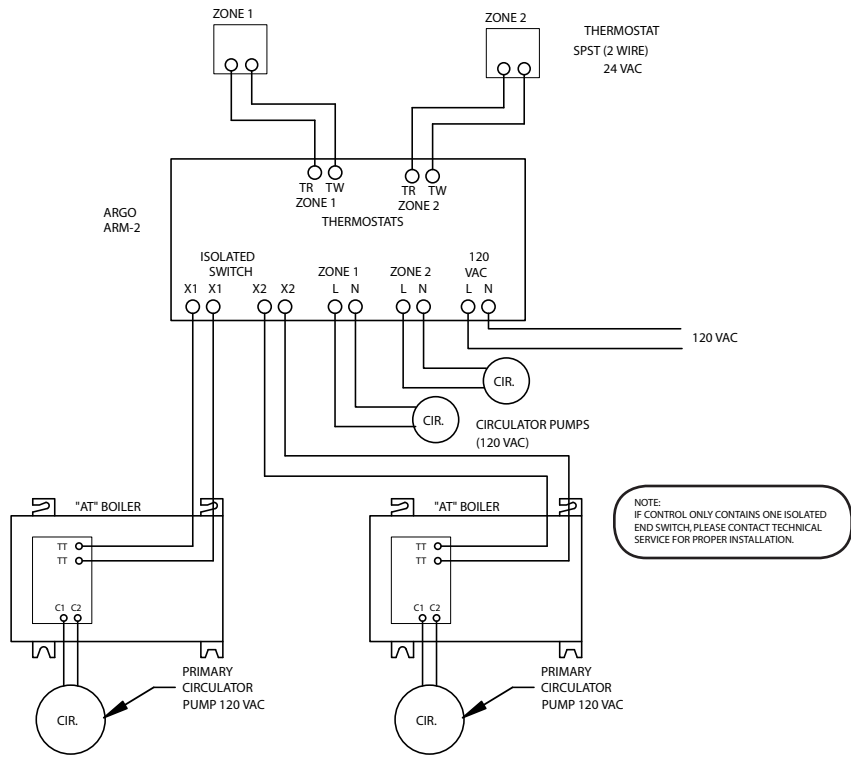

THREE ZONES WITH ZONE CONTROL VALVES 2 BOILERS

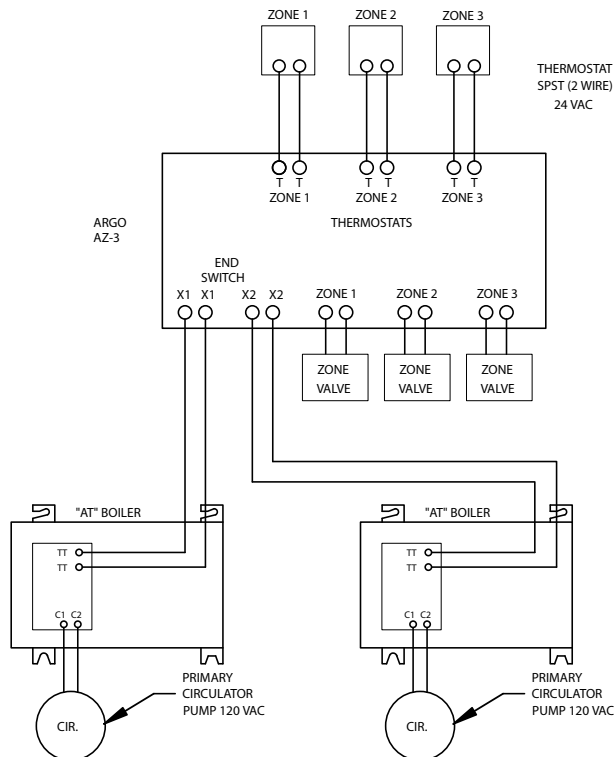

ADDITIONAL WIRING DIAGRAMS

THREE ZONES WITH CONTROL VALVES

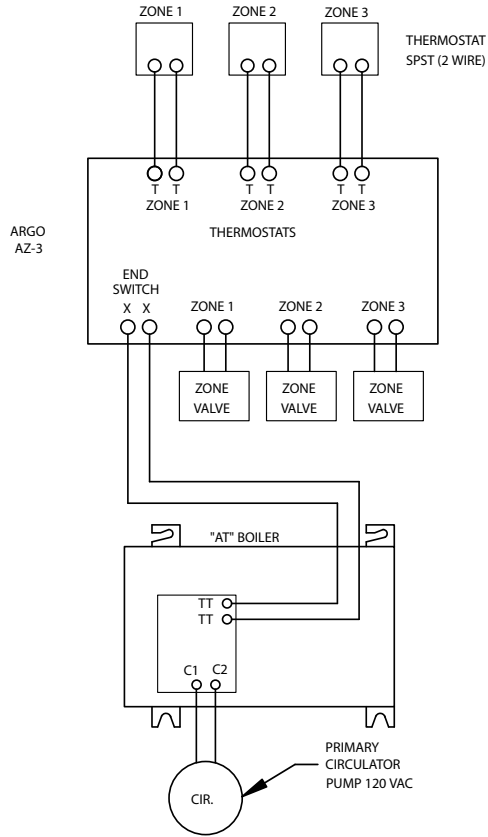

THREE ZONES WITH CIRCULATORS

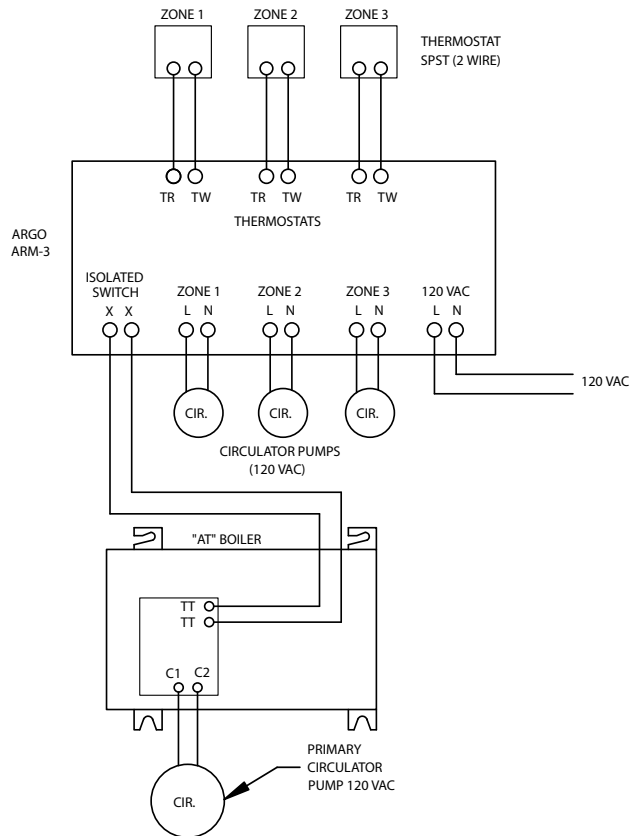

MODULAR BOILER PIPING

MODULAR BOILER PIPING

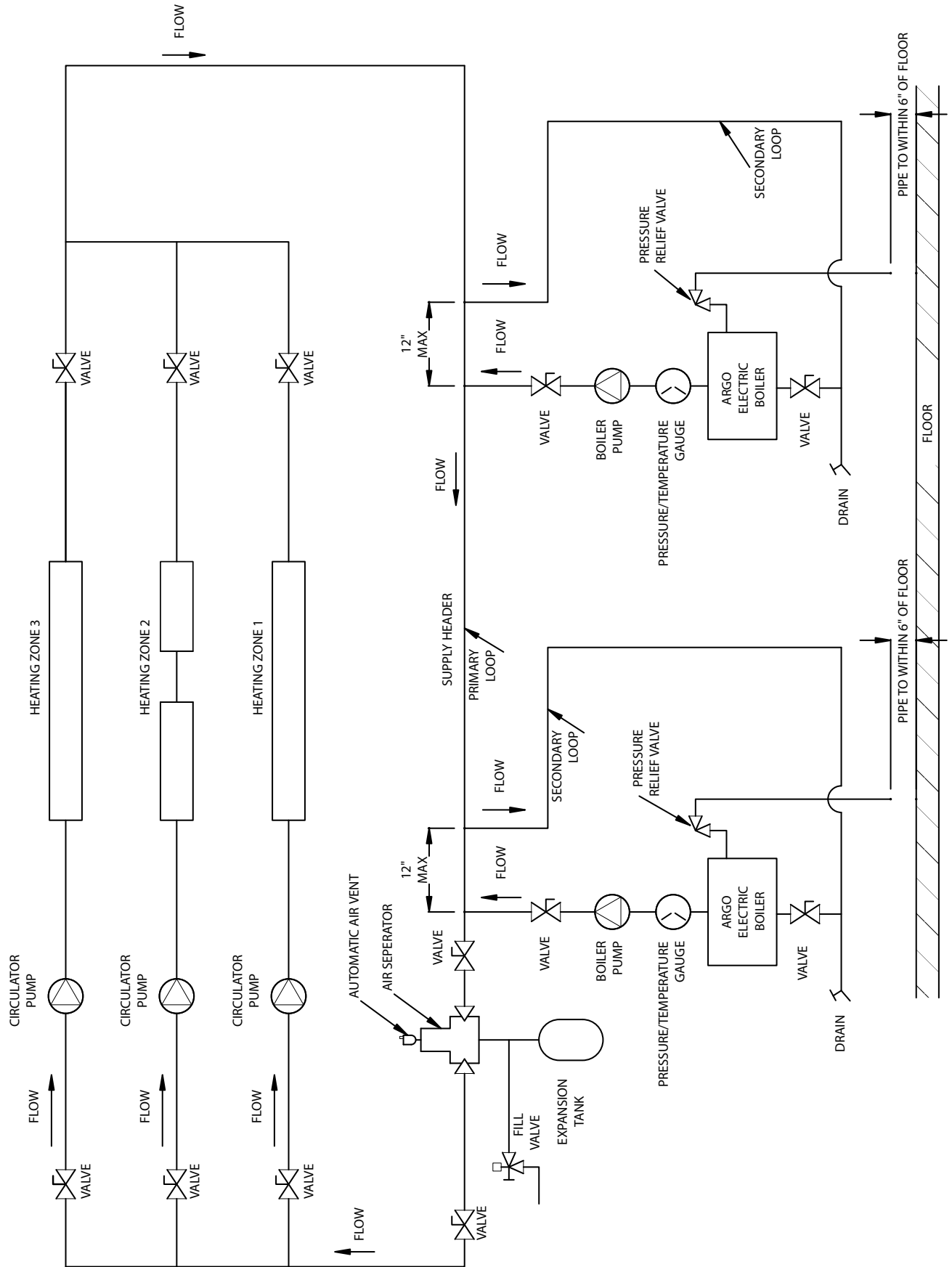

TROUBLESHOOTING - FLOWCHART#1



WARNING

Due to exposure to potentially dangerous voltages, troubleshooting should be performed by a qualified installer or service agency only. Failure to do so could result in property damage, personal injury, or loss of life.

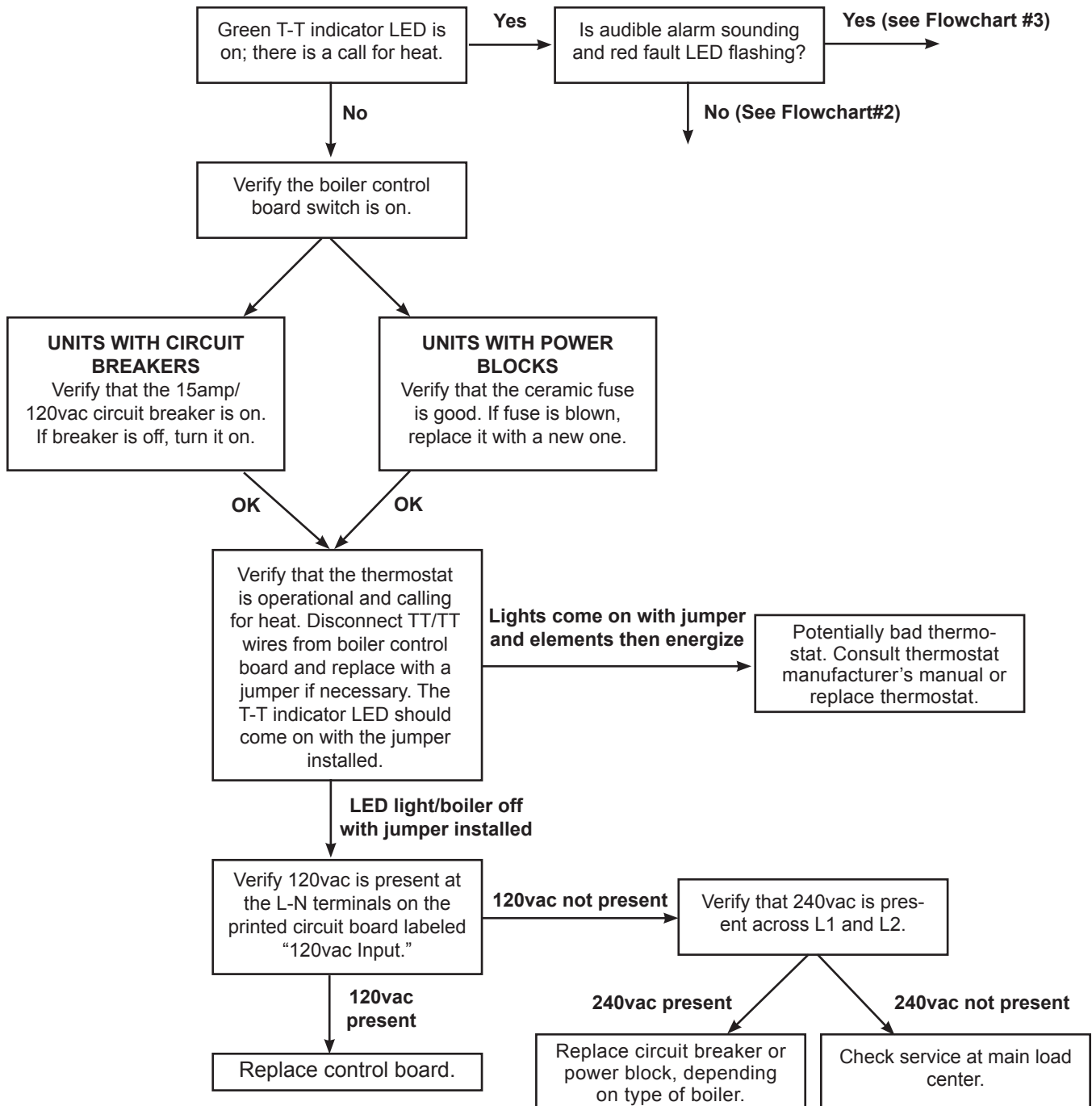

TROUBLESHOOTING - FLOWCHART#2

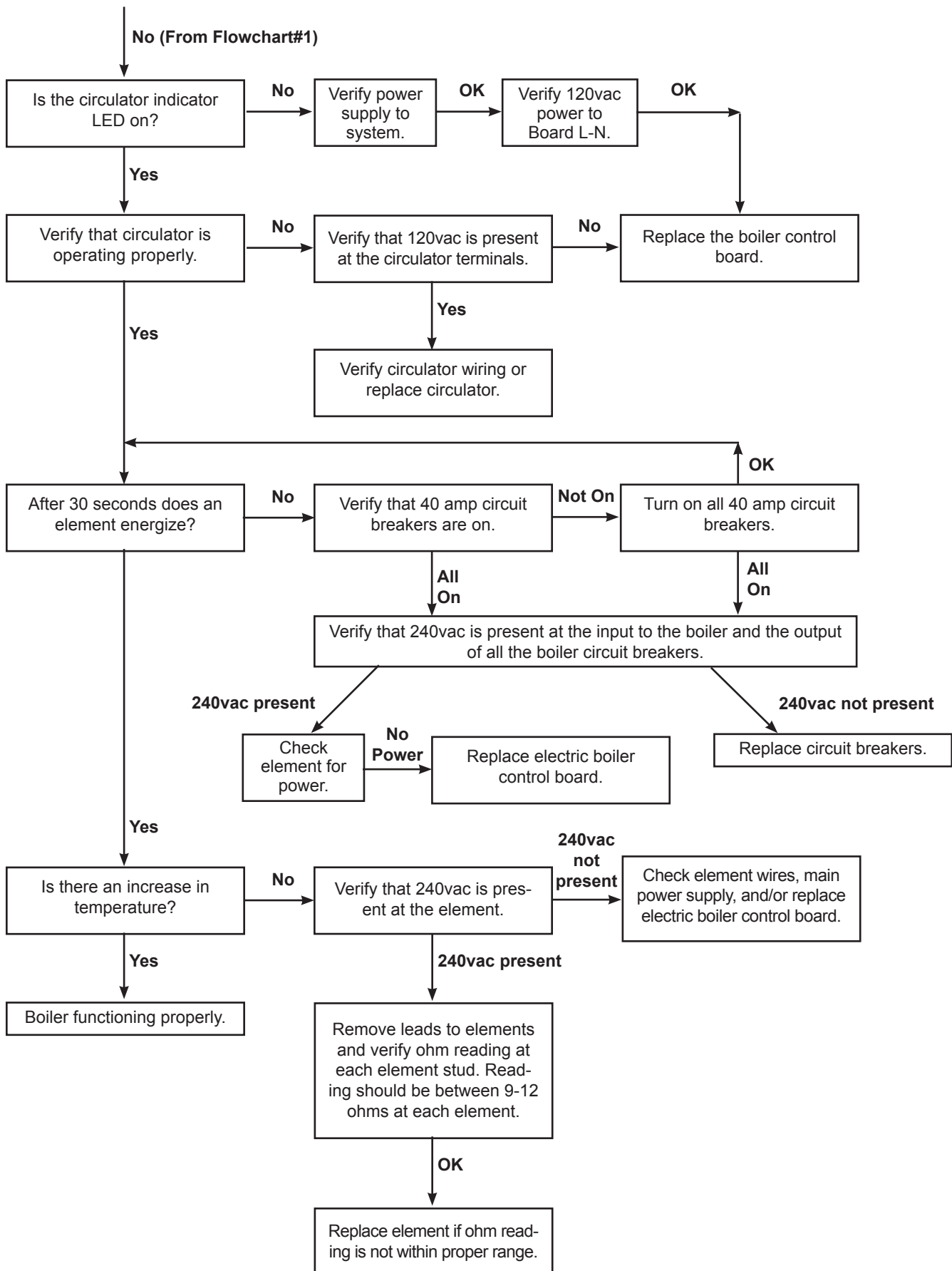

TROUBLESHOOTING - FLOWCHART#3

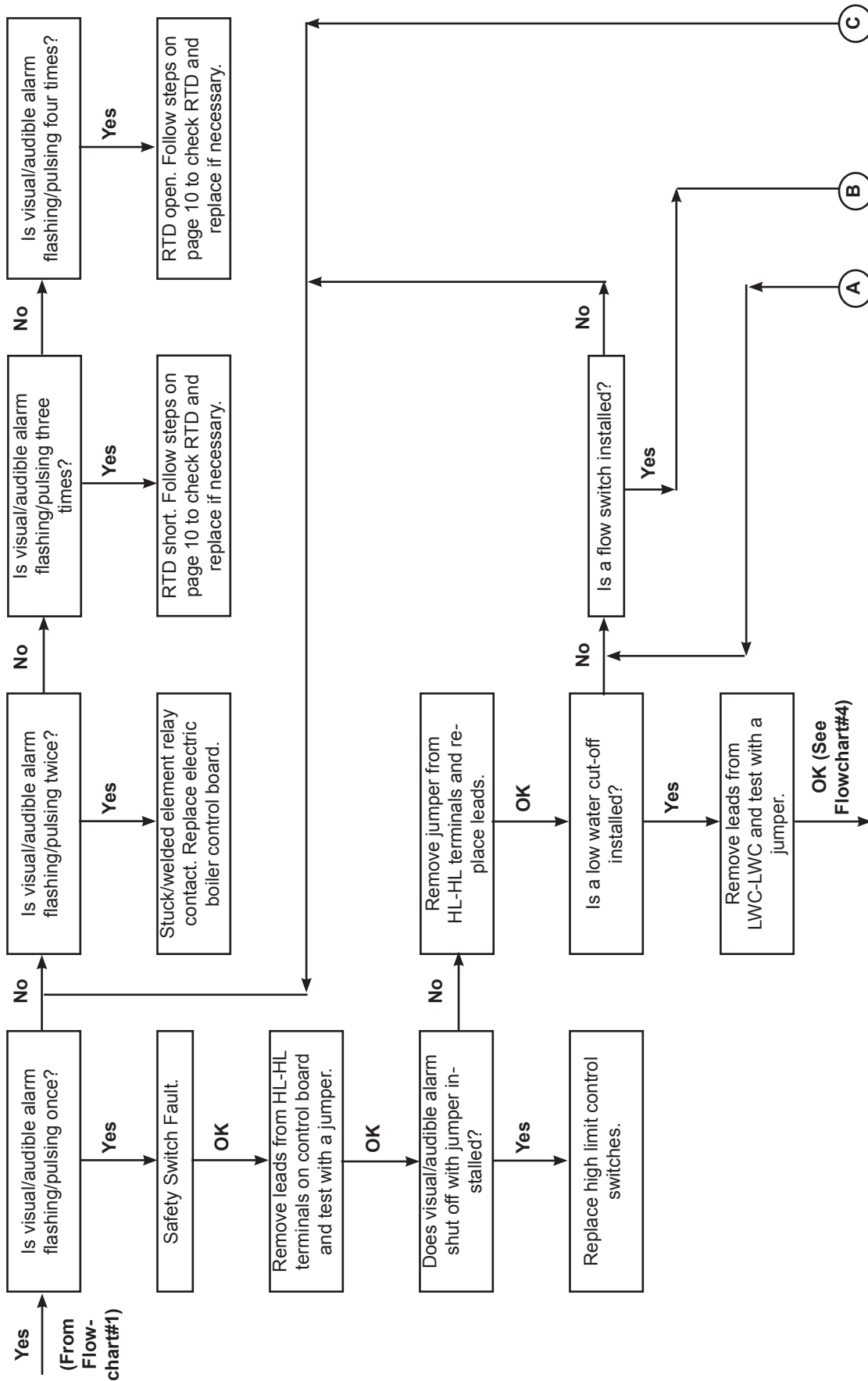

TROUBLESHOOTING - FLOWCHART#4

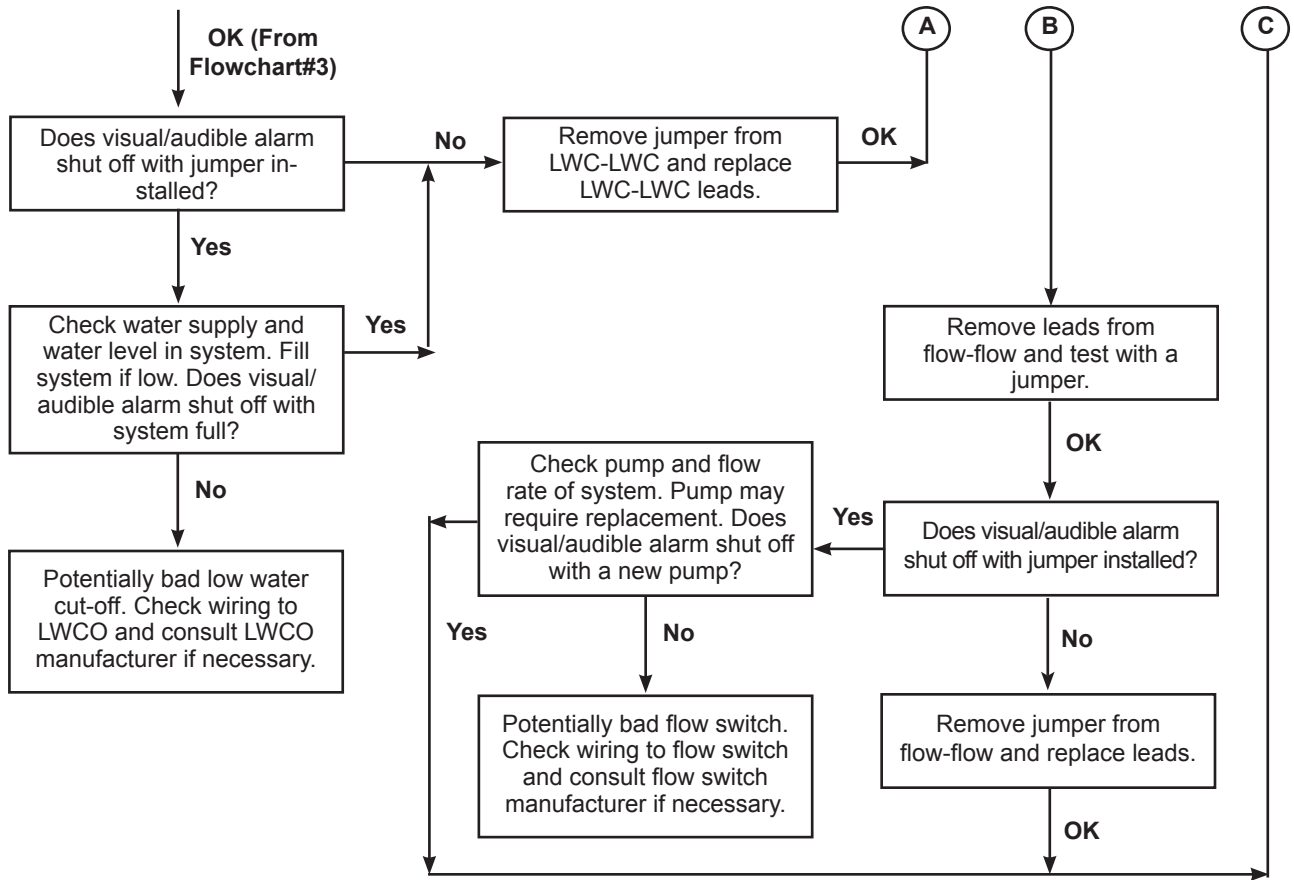

"AT" SERIES BOILER DIMENSIONS

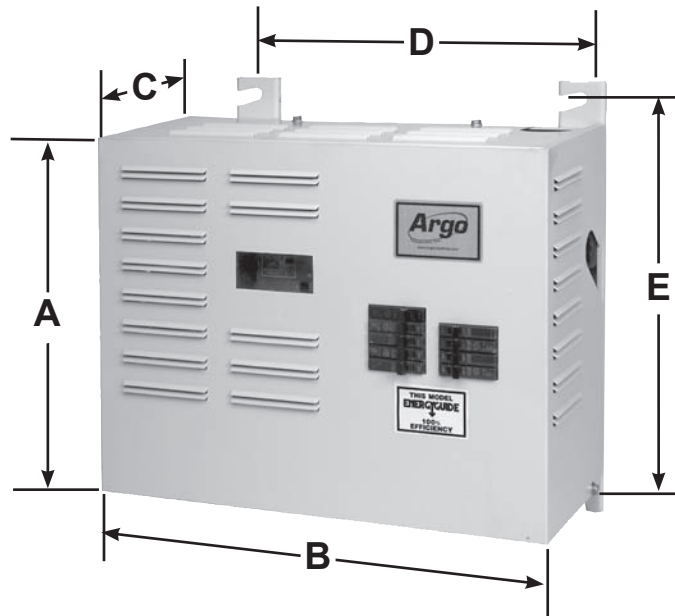

Dimensions					Inlet & Outlet Pipe Size	Approximate Shipping Wt.
A	B	C	D	E		
14-5/8"	18-5/8"	9-1/32"	14-3/8"	16-15/32"	1-1/4" NPT	70 lbs.

HOMEOWNER'S REFERENCE TABLE

Model Number: _____

Serial Number: _____

Date Installed: _____

Contractor: _____

Contact: _____

Address: _____

Telephone Number: _____

After Hours Number: _____

If different from Installation Contractor:

Service Tech: _____

Telephone Number: _____

After Hours Number: _____